



Simply Better Connections

## CL5808 / CL5816

8 / 16-Port VGA Dual Rail

LCD KVM Switch

User Manual

## Compliance Statements

---

### FEDERAL COMMUNICATIONS COMMISSION INTERFERENCE STATEMENT

This equipment has been tested and found to comply with the limits for a Class A digital device, pursuant to Part 15 of the FCC Rules. These limits are designed to provide reasonable protection against harmful interference when the equipment is operated in a commercial environment. This equipment generates, uses, and can radiate radio frequency energy and, if not installed and used in accordance with the instruction manual, may cause harmful interference to radio communications. Operation of this equipment in a residential area is likely to cause harmful interference in which case the user will be required to correct the interference at his own expense.

The device complies with Part 15 of the FCC Rules. Operation is subject to the following two conditions: (1) this device may not cause harmful interference, and (2) this device must accept any interference received, including interference that may cause undesired operation.

#### FCC Caution

Any changes or modifications not expressly approved by the party responsible for compliance could void the user's authority to operate this equipment.

#### Warning

Operation of this equipment in a residential environment could cause radio interference.

#### Achtung

Der Gebrauch dieses Geräts in Wohnumgebung kann Funkstörungen verursachen.



#### KCC Statement

유선 제품용 / A 급 기기 (업무용 방송 통신 기기)  
이 기기는 업무용 (A 급) 전자파적합기기로서 판매자 또는 사용자는 이  
점을 주의하시기 바라며, 가정 외의 지역에서 사용하는 것을 목적으로  
합니다.

#### RoHS

This product is RoHS compliant.

**警告使用者：**此為甲類資訊技術設備，於居住環境中使用時，可能會造成射頻擾動，在此種情況下，使用者會被要求採取某些適當的對策。

### KVM+ 多電腦切換器類產品

設備名稱 Equipment Name	16埠 PS/2-USB VGA 雙滑軌 LCD KVM 多電腦切換器		型號 ( 型式 ) Type designa- tion (Type)	CL5816		
單元 Unit	限用物質及其化學符號 Restricted substances and its chemical symbols					
	鉛 Lead (Pb)	汞 Mercury (Hg)	鎘 Cadmium (Cd)	六價鉻 Hexavalent chromium (Cr <sup>+6</sup> )	多溴聯苯 Polybrominated biphenyls (PBB)	多溴二苯醚 Polybrominated diphenyl ethers (PBDE)
電纜線 Cable	—	○	○	○	○	○
印刷電路部件 PCBA	—	○	○	○	○	○
塑膠 / 其他部件 Plastic / Other parts	○	○	○	○	○	○
螢幕 Panel	—	○	○	○	○	○
鍵盤 Keyboard	—	○	○	○	○	○
滑鼠 Mouse	—	○	○	○	○	○

備考 1. “超出 0.1 wt %”及“超出 0.01 wt %”係指限用物質之百分比含量超出百分比含量基準值。  
Note 1: “Exceeding 0.1 wt %” and “exceeding 0.01 wt %” indicate that the percentage content of the restricted substance exceeds the reference percentage value of presence condition.

備考 2. “○”係指該項限用物質之百分比含量未超出百分比含量基準值。  
Note 2: “○” indicates that the percentage content of the restricted substance does not exceed the percentage of reference value of presence.

備考 3. “—”係指該項限用物質為排除項目。  
Note 3: “—” indicates that the restricted substance corresponds to the exemption.

**製造商：**宏正自動科技股份有限公司

**地址：**新北市汐止區大同路二段 125 號三樓

**最大操作環境溫度：**40°C

**最大額定電壓：**100 - 240V AC



## **User Information**

---

### **Online Registration**

Be sure to register your product at our online support center:

---

International	<a href="http://eservice.aten.com">http://eservice.aten.com</a>
---------------	---

---

### **Telephone Support**

For telephone support, call this number:

---

International	886-2-8692-6959
China	86-400-810-0-810
Japan	81-3-5615-5811
Korea	82-2-467-6789
North America	1-888-999-ATEN ext 4988 1-949-428-1111

---

### **User Notice**

All information, documentation, and specifications contained in this manual are subject to change without prior notification by the manufacturer. The manufacturer makes no representations or warranties, either expressed or implied, with respect to the contents hereof and specifically disclaims any warranties as to merchantability or fitness for any particular purpose. Any of the manufacturer's software described in this manual is sold or licensed *as is*. Should the programs prove defective following their purchase, the buyer (and not the manufacturer, its distributor, or its dealer), assumes the entire cost of all necessary servicing, repair and any incidental or consequential damages resulting from any defect in the software.

The manufacturer of this system is not responsible for any radio and/or TV interference caused by unauthorized modifications to this device. It is the responsibility of the user to correct such interference.

The manufacturer is not responsible for any damage incurred in the operation of this system if the correct operational voltage setting was not selected prior to operation. PLEASE VERIFY THAT THE VOLTAGE SETTING IS CORRECT BEFORE USE.

## Product Information

---

For information about all ALTUSEN products and how they can help you connect without limits, visit ALTUSEN on the Web or contact an ALTUSEN Authorized Reseller. Visit ALTUSEN on the Web for a list of locations and telephone numbers:

International	<a href="http://www.aten.com">http://www.aten.com</a>
North America	<a href="http://www.aten-usa.com">http://www.aten-usa.com</a>

## Package Contents

---

Check to make sure that all the components are in working order. If you encounter any problem, please contact your dealer.

The CL5808 / CL5816's standard package consists of:

- ◆ 1 CL5808 / CL5816 LCD KVM Switch
- ◆ 2 custom KVM cables
- ◆ 1 5-in-1 console cable
- ◆ 1 firmware upgrade cable
- ◆ 1 power cord
- ◆ 1 standard rack mount kit
- ◆ 2 L brackets
- ◆ 1 user instructions

# Contents

---

Compliance Statements . . . . .	ii
User Information . . . . .	iv
Online Registration . . . . .	iv
Telephone Support . . . . .	iv
User Notice . . . . .	iv
Product Information . . . . .	v
Package Contents . . . . .	vi
Contents . . . . .	vii
About this Manual . . . . .	x
Conventions . . . . .	xi
<b>1. Introduction</b>	
Overview . . . . .	1
Features . . . . .	2
Requirements . . . . .	5
External Console . . . . .	5
Computers . . . . .	5
Cables . . . . .	5
Operating Systems . . . . .	6
Components . . . . .	7
Front View . . . . .	7
Keyboard Module . . . . .	8
LCD Module . . . . .	9
Rear View . . . . .	11
<b>2. Hardware Setup</b>	
Before you Begin . . . . .	13
Standard Rack Mount . . . . .	14
Front L-Brackets Mounting . . . . .	16
Optional Rack Mount Kits . . . . .	18
Single-Stage Installation . . . . .	19
Single-Stage Installation Diagram . . . . .	20
Cabling Diagrams . . . . .	21
Daisy Chaining . . . . .	22
Daisy Chain Installation Diagram . . . . .	23
<b>3. Basic Operation</b>	
Opening the Console . . . . .	25
Opening Separately . . . . .	25
Opening Together . . . . .	27
Closing the Console . . . . .	28
Operating Precautions . . . . .	30
Powering Off and Restarting . . . . .	31

LCD OSD Configuration	32
The LCD Buttons	32
LCD Adjustment Settings	33
Hot Plugging	34
Hot Plugging Stations	34
Hot Plugging KVM Ports	34
Hot Plugging Console Ports	34
Port Switching	35
Manual Port Switching	35
Port ID Numbering	36
USB Peripheral Devices	36

## 4. OSD Operation

Overview	37
Manufacturing Number	37
Logging In	37
OSD Main Screen	37
OSD Main Screen Headings	39
OSD Navigation	39
OSD Functions	40
F1: GOTO	40
F2: LIST	41
F3: SET	42
F4: ADM	44
F5: SKP	48
F6: BRC	49
F7: SCAN	49
F8: LOUT	50

## 5. Keyboard Port Operation

Hotkey Port Control	51
Hotkey Mode	52
Invoking Hotkey Mode	52
Hotkey Mode Active	52
Exiting Hotkey Mode	52
Selecting the Active Port	53
Auto Scan Mode	54
Invoking Auto Scan	54
Exiting Auto Scan	54
Pausing Auto Scan	54
Skip Mode	55
Invoking Skip Mode	55
Exiting Skip Mode	55
Computer Keyboard/Mouse Reset	56
Hotkey Beeper Control	56



Hotkey Invocation Key Selection . . . . .	57
OSD Hotkey Selection . . . . .	57
Port OS Selection . . . . .	58
Set USB Speed . . . . .	58
Restore the Default Values . . . . .	59
Hotkey Summary Table . . . . .	60
<b>6. Keyboard Emulation</b>	
Mac Keyboard . . . . .	61
Sun Keyboard . . . . .	62
<b>7. The Firmware Upgrade Utility</b>	
Introduction . . . . .	63
Downloading the Firmware Upgrade Package . . . . .	63
Preparation . . . . .	64
Starting the Upgrade . . . . .	65
Upgrade Succeeded . . . . .	67
Upgrade Failed . . . . .	68
<b>Appendix</b>	
Safety Instructions . . . . .	69
General . . . . .	69
Rack Mounting . . . . .	71
Consignes de sécurité . . . . .	72
Général . . . . .	72
Montage sur bâti . . . . .	75
Technical Support . . . . .	76
International . . . . .	76
North America . . . . .	76
Specifications . . . . .	77
Connection Tables . . . . .	81
CL5808 to Compatible 8-Port Switches . . . . .	81
CL5808 to Compatible 16-Port Switches . . . . .	81
CL5816 to Compatible 8-Port Switches . . . . .	82
CL5816 to Compatible 16-Port Switches . . . . .	82
Supported KVM Switches . . . . .	83
Clear Login Information . . . . .	84
OSD Factory Default Settings . . . . .	85
Troubleshooting . . . . .	85
Overview . . . . .	85
Keyboard Invocation Keys . . . . .	86
About SPHD Connectors . . . . .	87
Limited Warranty . . . . .	88

## About this Manual

---

This manual is provided to help you get the most out of your CL5808 / CL5816. It covers all aspects of the device, including installation, configuration, and operation.

The LCD KVM switch models covered in this manual include:

Model	Product Name
CL5808	8-Port PS/2-USB VGA Dual Rail LCD KVM Switch
CL5816	16-Port PS/2-USB VGA Dual Rail LCD KVM Switch

An overview of the information found in the manual is provided below.

**Chapter 1, Introduction**, introduces you to the CL5808 / CL5816, its purpose, features, and benefits, with its front and back panel components described.

**Chapter 2, Hardware Setup**, describes how to set up the CL5808 / CL5816, and the necessary steps — from a basic single-stage hookup to a complete 32-switch daisy-chained operation.

**Chapter 3, Basic Operation**, explains the fundamental concepts involved in operating the CL5808 / CL5816.

**Chapter 4, OSD Operation**, provides a complete description of the CL5808 / CL5816's OSD (On Screen Display), and the various functions provided.

**Chapter 5, Keyboard Port Operation**, details all of the concepts and procedures involved in the hotkey operation of your CL5808 / CL5816 installation.

**Chapter 6, Keyboard Emulation**, provides tables that list the PC-to-Mac and PC-to-Sun keyboard emulation mappings.

**Chapter 7, The Firmware Upgrade Utility**, explains how to upgrade the CL5808 / CL5816's firmware to the latest available versions using the firmware upgrade utility.

**Appendix**, provides the specifications and other technical information at the end of the manual.

**Note:**

- ♦ Read this manual thoroughly and follow the installation and operation procedures carefully to prevent any damage to the unit or connected devices.
  - ♦ The product may be updated, with features and functions added, improved, or removed since the release of this manual. For an up-to-date user manual, visit <http://www.aten.com/global/en/>
- 

**Conventions**

This manual uses the following conventions:

Monospaced	Indicates text that you should key in.
[ ]	Indicates keys you should press. For example, [Enter] means to press the <b>Enter</b> key. If keys need to be chorded, they appear together in the same bracket with a plus sign between them: [Ctrl+Alt].
1.	Numbered lists represent procedures with sequential steps.
♦	Bullet lists provide information, but do not involve sequential steps.
>	Indicates selecting consecutive options (such as on a menu or dialog box). For example, Start > Run means to open the <i>Start</i> menu, and then select <i>Run</i> .
	Indicates critical information.

This Page Intentionally Left Blank

# Chapter 1

## Introduction

### Overview

---

The CL5808 / CL5816 LCD KVM Switch is a keyboard, video, and mouse (KVM) switch, integrated with an LCD console, that offers secure access to 8 / 16 computers, and is mountable within a 1U rack space.

The CL5808 / CL5816's 19" LED-backlit LCD monitor and keyboard / touchpad can be slid independently of each other. To maximize space in your data center, the keyboard / touchpad module can be slid back and "hid away" when not in use, while the LCD monitor can be rotated back — flush against the rack — allowing convenient monitoring of the connected computers. For added convenience, it also supports an external USB mouse and an extra console port is provided on the rear panel to manage the LCD KVM switch from an optional external console (monitor, keyboard, and mouse). The CL5808 / CL5816 supports both PS/2 and USB keyboard and mouse interfaces for the connected computers, as well as USB peripheral devices to be used with the attached computers. As many as 31 additional compatible KVM switches can be daisy-chained so that up to 256 / 512 computers can all be controlled from a single keyboard, monitor, and mouse console (see the Appendix for a list of compatible ATEN switches).

The CL5808 / CL5816 is built with a modular design. The KVM section can be detached from the switch section for convenient maintenance and repair.

There are two models in the series as outlined in the following table:

Model	LCD Panel	KVM Ports	Power
CL5808N	19"	8	AC
CL5816N	19"	16	AC

Your CL5808 / CL5816 investment is protected by an included firmware upgrade utility, allowing you to stay up-to-date with the latest functionality improvements by downloading firmware update files from our website as they become available, and using the utility to quickly and conveniently perform the upgrade.

Setup is fast and easy — plugging cables into their appropriate ports is all that is entailed. There is no software configuration required, with no need to get involved in complex installation routines.

Access to any computer connected to the installation can be easily accomplished by any of the following methods: by entering hotkey combinations from the keyboard or via a powerful, menu-driven OSD (on-screen display). A convenient *Auto Scan* feature also permits automated monitoring by alternating views among the selected computers at set intervals.

There is no better way to save time and money than with a CL5808 / CL5816 installation. By using the CL5808 / CL5816 with its sliding LCD console to manage your installation, you can eliminate the expense, space, and efforts required of having to purchase a separate keyboard, monitor, and mouse for each computer.

## Features

---

- ◆ Exclusive LED illumination light — illuminates the keyboard and touchpad for operation under low-light conditions
- ◆ Integrated KVM console with 19” LED-backlit LCD in a dual-rail Slideaway™ housing
- ◆ LCD module rotates up to 120 degrees for a more comfortable viewing angle
- ◆ Space saving — up to two consoles (one bus) control up to 8 / 16 computers
- ◆ Daisy chain up to 31 additional units — control up to 256 (CL5808) / 512 (CL5816) computers from a single console
- ◆ Dual interface — supports computers with PS/2 and USB keyboard and mouse interfaces
- ◆ USB port — allows each connected computer to access an attached USB peripheral\*
- ◆ Multiplatform support — Windows, Linux, Mac, and Sun
- ◆ Supports multimedia USB keyboards for PC, Mac, and Sun
- ◆ Auto PS/2 and USB interface detection

- ◆ Keyboard and mouse emulation (PS/2 and USB) for smooth switching and simultaneous booting of multiple computers even when the console focus is elsewhere
- ◆ Superior video quality — supports resolutions of up to 1280 x 1024 @ 75 Hz
- ◆ No software required — convenient computer selection via menu-driven, intuitive OSD (on-screen display) and Hotkeys
- ◆ Auto-senses station's position on daisy-chained installations; no need for manual DIP switch setting; front panel LED indicates the station's position
- ◆ Port names automatically reconfigured when station sequence is changed
- ◆ Two-level password security — authorized users view and control computers
- ◆ Supports one administrator and four user accounts with separate profiles
- ◆ Auto Scan mode enables automated monitoring of user-selected computers
- ◆ Broadcast support — commands from the keyboard can be broadcasted to all connected computers on the installation
- ◆ Hot pluggable — add or remove computers without having to power down the switch
- ◆ Beeper on/off via hotkey and OSD
- ◆ Firmware upgrades to all chained KVM switches at the same time via the daisy chain cable

---

\* Only for computers connected with USB KVM cables.

---

- ◆ Extra console port — for managing computers from an external console (monitor, USB or PS/2 keyboard, and mouse)
- ◆ Supports external USB mouse
- ◆ Convenient direct port selection pushbuttons (8 / 16) — each with 2 LEDs indicating whether the server is powered and selected.
- ◆ Station up/down navigation buttons with a 2 x 7 segment LED display indicating the currently selected station of a daisy-chained installation.
- ◆ Port navigation buttons located on the front LCD panel for quick port switching when the keyboard module is in the Slideaway™ position behind and hidden.
- ◆ Dedicated *Hotkey* mode and *OSD Invocation Keys* provide quick access to related functions

- ◆ OSD tree structure makes finding and managing computers easy
- ◆ Console lock — enables the console drawer to remain securely locked away when not in use
- ◆ OSD port list automatically expands when new stations are added
- ◆ Security — administrator / user password authentication for enhanced security protection; administrator access rights synchronized between first and chained stations
- ◆ OSD screen automatically adjusts to resolution changes
- ◆ Two types of logout: manual and timed
- ◆ Slideaway™ housing is slightly less than 1U with top and bottom clearance for smooth operation in 1U of rack space
- ◆ DDC emulation — video settings of each computer are automatically adjusted for optimal output to the monitor
- ◆ Standard 105-key keyboard
- ◆ Keyboard status restored when switching between computers
- ◆ Keyboard languages supported: English (US), English (UK), French, German, German (Swiss), Greek, Hungarian, Italian, Japanese, Korean, Russian, Spanish, Swedish and Traditional Chinese
- ◆ Optional rack mount kits available, including easy installation options



# Requirements

---

## External Console

The following hardware components are required for the external console:

- ◆ A VGA, SVGA, or multisync monitor capable of displaying the highest resolution provided by any computer in the installation.
- ◆ A USB or PS/2 keyboard and mouse

## Computers

The following equipment must be installed on each computer:

- ◆ A VGA, SVGA, or multisync video graphics card with an HDB-15 port.

---

**Note:** The integrated LCD monitor's maximum resolution is 1280 x 1024 @ 75 Hz. Make sure that none of the computer resolution settings exceed the LCD monitor's maximum resolution.

---

- ◆ PS/2 mouse and keyboard ports (6-pin Mini-DIN), or at least one USB port.
- ◆ Direct support Sun USB systems; or, for Sun legacy systems, an ATEN CV130A Sun Console Converter.

## Cables

Substandard cables may damage the connected devices or affect their overall performance. For optimum signal integrity and simplified layout, we strongly recommend the use of the high-quality CS custom cable sets described below:

Function	Length	Part Number
KVM switch to KVM switch (Daisy chaining)	0.6 m	2L-1700
	1.8 m	2L-1701
	3.0 m	2L-1703
	5.0 m	2L-1705
	15.0 m	2L-1715
USB KVM cables	1.2 m	2L-5201U
	1.8 m	2L-5202U
	3.0 m	2L-5203U
	5.0 m	2L-5205U
PS/2 KVM cables	1.2 m	2L-5201P
	1.8 m	2L-5202P / 2L-5702P
	3.0 m	2L-5203P
	6.0 m	2L-5206P

PS/2-USB KVM cables	1.2 m	2L-5301UP
	1.8 m	2L-5302UP
	3.0 m	2L-5303UP

---

## **Operating Systems**

Supported operating systems are shown in the table below:

<b>OS</b>		<b>Version</b>
Windows		2000 or later
Linux	RedHat	7.1 or later
	SuSE	9.0 or later
	Mandriva (Mandrake)	9.0 or later
UNIX	AIX	4.3 or later
	FreeBSD	4.2 or later
	Sun	Solaris 8 or later
Novell	Netware	5.0 or later
Mac		OS 9 or later
DOS		6.22

# Components

## Front View

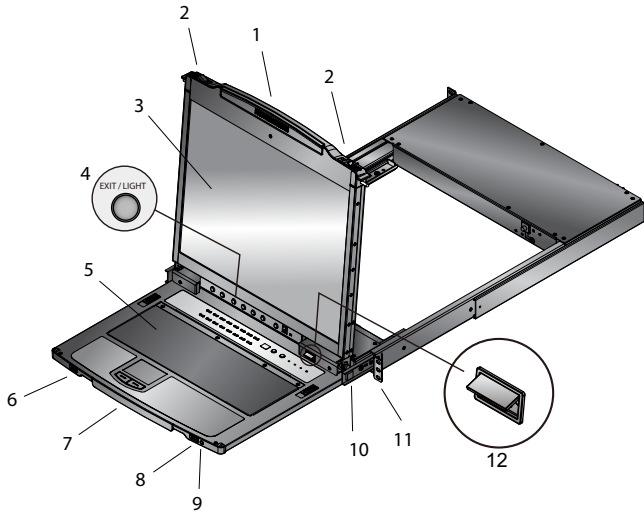

No.	Component	Description
1	upper handle	Pull to slide the LCD module out; push to slide it in. See <i>Opening the Console</i> , page 25, for details on sliding the console in and out.
2	module release catches	In order to slide the console out, you must first release it by sliding these catches to the inside.
3	LCD module	See <i>LCD Module</i> , page 9.
4	exit / light Pushbutton	Press this pushbutton for two seconds to turn the LED Illumination Light on or off (default: on). During the LCD OSD mode, this pushbutton has more functions, refer to <i>The LCD Buttons</i> on page 32 for more details.
5	keyboard module	See <i>Keyboard Module</i> , page 8.
6	USB port	The USB port is available to connect a USB 1.1 peripheral device (flash drive, CD-ROM drive, etc.) to the switch.
7	lower handle	Pull to slide the keyboard module out; push to slide it in.
8	external mouse port	A USB mouse port is provided for users who prefer to use an external mouse.
9	power LED	Lights (blue) to indicate that the unit is receiving power.
10	LCD release catch	These catches (one on each side) release the LCD module so that you can slide it away.

No.	Component	Description
11	rack mount brackets	The rack mount brackets are located at each corner of the unit. See <i>Standard Rack Mount</i> , page 14, for details.
12	LED illumination light	Illuminates the keyboard and touchpad to allow visibility in low-light conditions.

## Keyboard Module

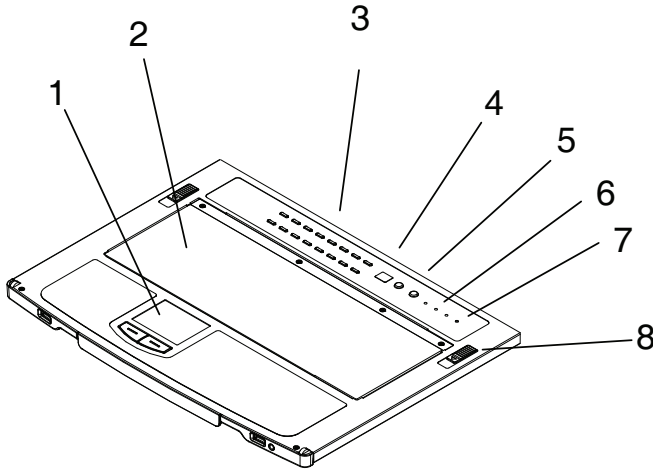

No.	Component	Description
1	touchpad	Standard mouse touchpad
2	keyboard	Standard 105-key keyboard
3	port selection buttons and LEDs	To access a port on the currently selected Station press its corresponding port selection button. Indicator LEDs are built into the switches: <ul style="list-style-type: none"> <li>◆ An <b>On Line</b> LED lights to indicate that the computer attached to its corresponding port is up and running.</li> <li>◆ A <b>Selected</b> LED lights to indicate which port has the KVM focus.</li> </ul>
4	station ID LED	In a daisy chained installation, the Station ID of the currently selected station displays as a 2 digit figure in this panel. See <i>Manual Port Switching</i> , page 35 for further details.

No.	Component	Description
5	station selection buttons	In a daisy chained installation, press the UP or DOWN button to cycle to the desired station. <ul style="list-style-type: none"> <li>◆ The left (DOWN) button shifts the KVM focus down the chain (station 2 → station 1, etc.). After station 1, it cycles back to the last station.</li> <li>◆ The right (UP) button shifts the KVM focus up the chain. After the last station, it cycles to station 1.</li> </ul>
6	lock LEDs	Num Lock, Caps Lock, Scroll Lock LEDs are located here.
7	reset button	Located to the right of the Lock LEDs. Press this button in with a small object to perform a system reset.
8	keyboard release catch	These catches (one on each side) release the keyboard / touchpad module so you can slide it away.

## LCD Module

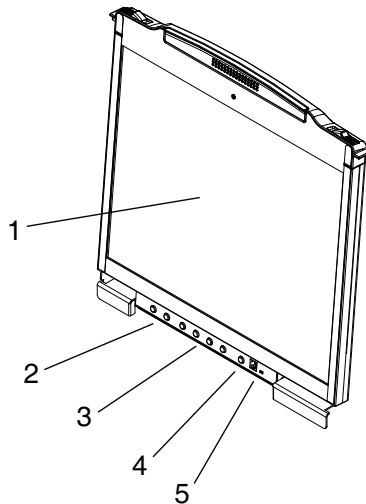

No.	Component	Description
1	LCD display	After sliding the LCD module out, flip up the cover to access the LCD monitor.

No.	Component	Description
2	port navigation switches	<p>These buttons can be used to access a port when the keyboard module isn't extended. Press the UP or DOWN button to cycle forward or backward through the ports.</p> <ul style="list-style-type: none"><li>◆ The left (DOWN) button shifts the KVM focus down the chain (port 2 → port 1, etc.). After port 1, it cycles to the last port.</li><li>◆ The right (UP) button shifts the KVM focus up the chain. After the last port, it cycles back to port 1.</li></ul>
3	LCD OSD controls	<p>Buttons to control the position and picture settings of the LCD display are located here. See <i>LCD OSD Configuration</i>, page 32, for details.</p>
4	LCD power button	<p>Press this button to turn the LCD monitor on and off. When the LCD monitor is off, this button illuminates; when the LCD monitor is on, this button does not illuminate. (This function only affects the monitor, not the KVM switch itself.)</p>
5	firmware upgrade section	<ul style="list-style-type: none"><li>◆ Firmware upgrade port: The firmware upgrade cable that transfers the firmware upgrade data from the administrator's computer to the CL5808 / CL5816 plugs into this RJ-11 connector.</li><li>◆ Firmware upgrade switch: During normal operation this switch should be in the NORMAL position. (See <i>The Firmware Upgrade Utility</i>, page 63 for firmware upgrading details.)</li></ul>

---

## Rear View

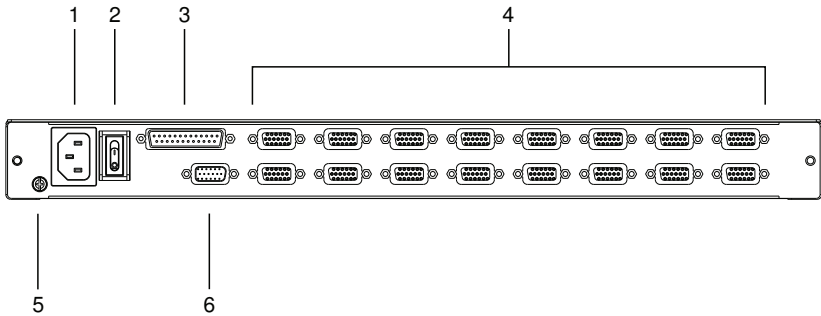

No.	Component	Description
1	power socket	This is a standard 3-prong AC power socket. The power cord from an AC source plugs in here.
2	power switch	This standard rocker switch powers the unit on and off.
3	daisy chain port	When daisy chaining units, the daisy chain cable plugs in here.
4	KVM port section	The cables that link to the computers plug in here. <b>Note:</b> The shape of these SPHD connectors has been specifically modified so that only KVM cables designed to work with this switch can plug in (see <i>Cables</i> , page 5 for details). Do <b>NOT</b> attempt to use ordinary 15 pin VGA connector cables to link these ports to the computers.
5	grounding terminal	The grounding wire used to ground the switch attaches here.
6	external console port	For flexibility and convenience, the CL5808 / CL5816 supports an independent, external, KVM console. If you choose to install an external console, the console cable (supplied with the CL5808 / CL5816 package), plugs in here.

This Page Intentionally Left Blank



## Chapter 2

# Hardware Setup

### Before you Begin

---



1. Important safety information regarding the placement of this device is provided on page 69. Please review it before proceeding.
2. Make sure the power to all devices to be connected has been turned off. You must unplug the power cords of any computers with Keyboard Power-On function.
3. Packing material has been inserted to protect the CL5808 / CL5816 during shipping. Slide the LCD module out (see *Opening the Console*, page 25, for details) until the packing material is visible. Remove the packing material before installing the unit, as shown in the diagram below.

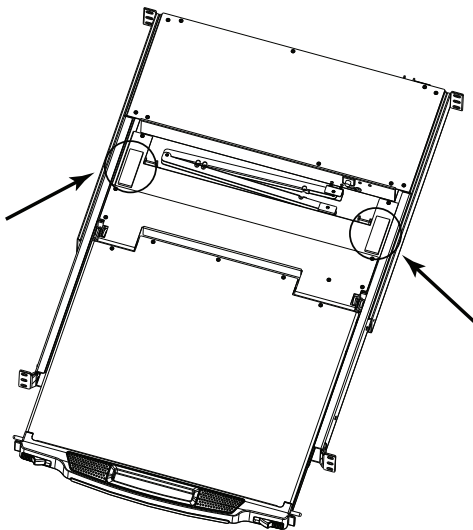



4. Please operate the device with caution when under high environmental temperatures, as the surface of the device may become overheated under such conditions. For instance, the surface temperature of the device may reach 70 °C or higher when the environmental temperature reaches close to 50 °C.

## Standard Rack Mount

---

A standard rack mount kit is provided with your CL5808 / CL5816. The kit enables the CL5808 / CL5816 to be mounted onto a rack with a depth of 52 – 85 cm.

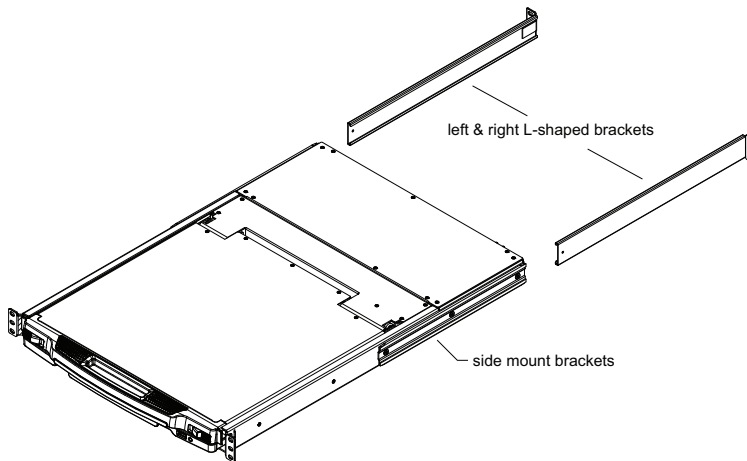

- 
- Note:**
- ◆ It takes two people to mount the console.
  - ◆ The standard rack mount kit does not include screws or cage nuts. If you need additional screws or cage nuts, contact your rack dealer.
-

To rack mount the CL5808 / CL5816, do the following:

1. Have one person position the unit in the rack and hold it steady. Have a second person screw the front brackets to the rack.

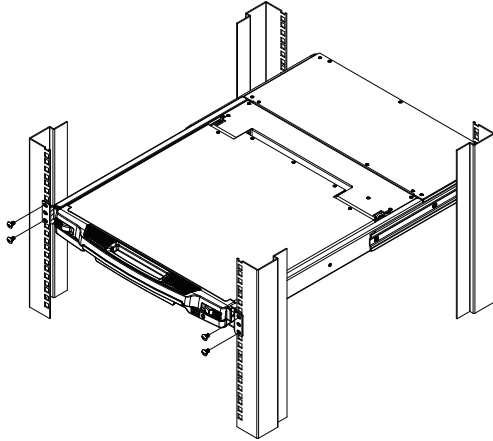

2. While the first person still holds the unit in place, the second person slides the left & right L-shaped brackets into the unit's side mounting brackets from the rear, installing four screws in the brackets to secure them in place.

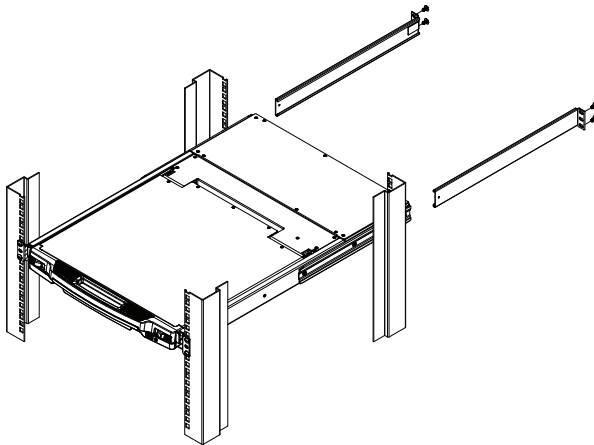

3. After the L-shaped brackets are secured, tighten all the screws.  
Allow at least 5.1 cm of clearance on each side for proper ventilation, and at least 12.7 cm at the back for the power cord and cables.

## Front L-Brackets Mounting

For enhanced stability, install the front L-brackets to provide an extension at the front of the rack for sliding the unit further out and enabling the LCD screen to be tilted to a greater degree. Instructions to use this option are shown below:

1. Attach the left and right front L-brackets to the front of the rack, placing screws in the tabs to secure them in place.

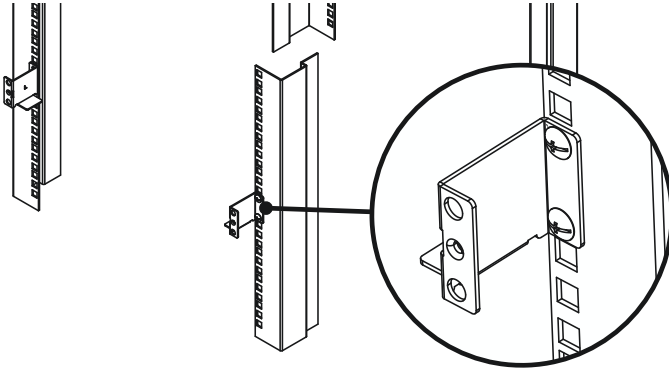

**Note:** Rack screws are not provided to mount the unit. We recommend that you use M5 x P0.8 screws.

2. Have one person position the unit in the rack and hold it steady. Have a second person screw the front brackets to the front-L bracket.

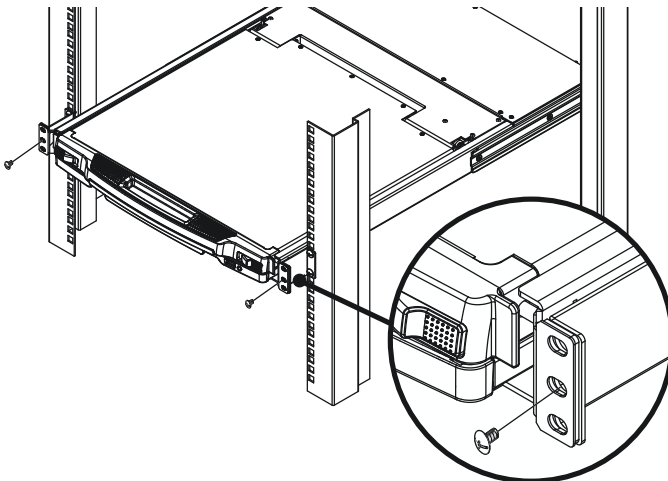

3. While the first person still holds the unit in place, the second person slides the left & right L-shaped brackets into the unit's side mounting brackets from the rear, installing four screws in the brackets to secure them in place.

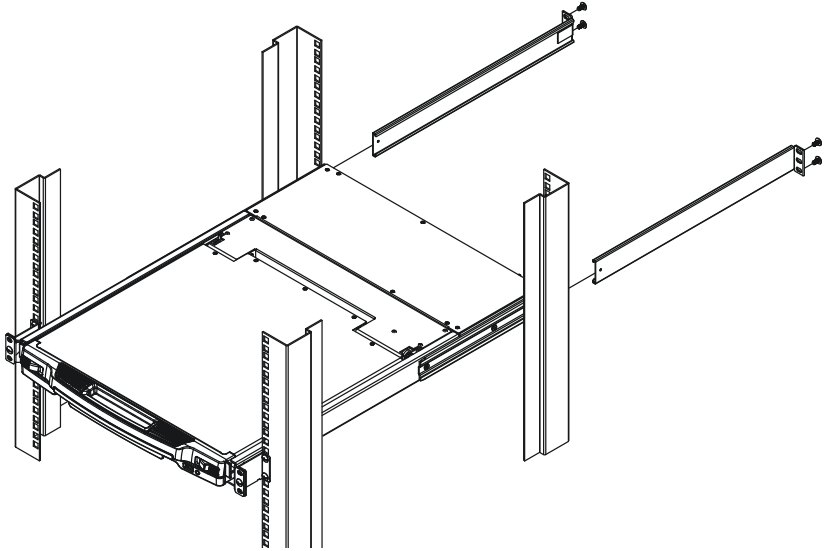

4. After the L-shaped brackets are secured, tighten all the screws.  
Allow at least 5.1 cm of clearance on each side for proper ventilation, and at least 12.7 cm at the back for the power cord and cables.

## Optional Rack Mount Kits

---

Optional rack mount kits are available and are listed in the table below:

Mounting Kit	Description
Standard Long Rack Mount Kit	This kit is the long-railed version of your standard rack mount kit that lets you fit your device to racks with greater depth.
Easy Installation Rack Mount Kit	This kit is designed to easily install the unit without requiring more than one person

- 
- Note:**
- ◆ For more information, visit the product webpage and refer to the *Compatible Accessories*.
  - ◆ For detailed installation steps, visit the product webpage and refer to the *Optional Rack Mount Kits Installation Guide*.
-

## Single-Stage Installation

---

In a single-stage installation, there are no additional switches daisy-chained from the first unit. To set up a single-stage installation, refer to the installation diagrams on the following pages (the numbers in the diagrams correspond to the installation step numbers), and do the following:

1. Ground the CL5808 / CL5816 by connecting one end of a grounding wire to the grounding terminal and the other end of the wire to a suitable grounded object.

---

**Note:** Do not omit this step. Proper grounding helps to prevent damage to the unit from surges or static electricity.

---

2. If you choose to connect an external console to the CL5808 / CL5816, use the console cable provided to plug a keyboard, monitor, and mouse into the *console port*. See *Console Cable Installation Diagram*, page 21.

---

**Note:** 1. Connecting an external console is optional.

2. You can use any combination of keyboard and mouse connections. For example, you can use a PS/2 keyboard with a USB mouse.
- 

3. For each of the computers you are installing, use a KVM cable set (as described in the *Cables* section on page 5), to connect any available KVM port to the computer's keyboard, video and mouse ports. See *KVM Cable Installation Diagrams*, page 21.
4. Plug the power cord into the CL5808 / CL5816 power socket and into an AC power source.

After you have completed the installation procedures, power on the CL5808 / CL5816 (see *Powering Off and Restarting*, page 31 for details). After the CL5808 / CL5816 is powered on, power on the computers.

## Single-Stage Installation Diagram

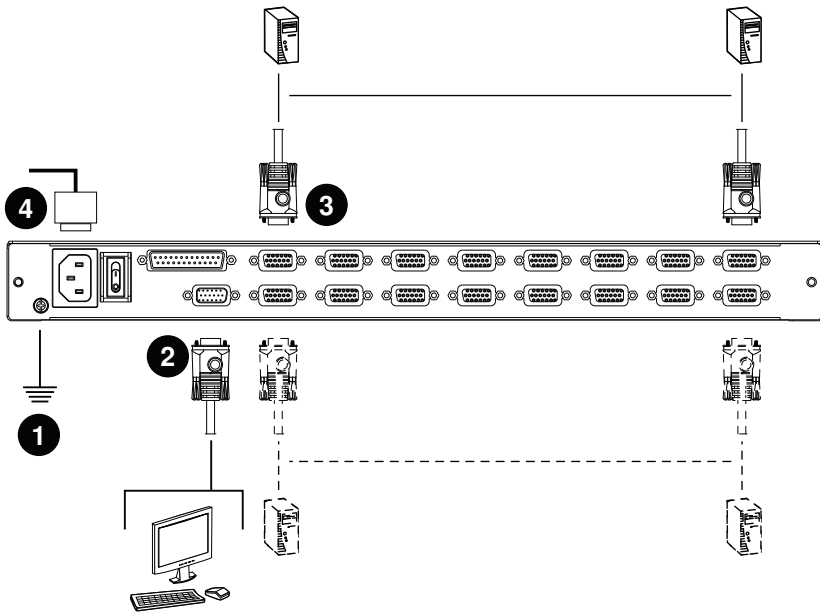



## Cabling Diagrams

### Console Cable Installation Diagram

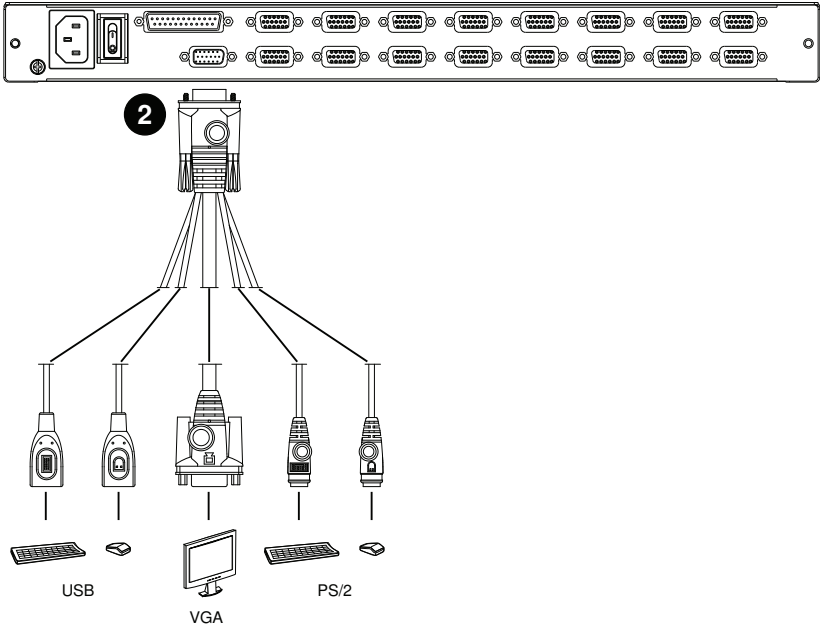

### KVM Cable Installation Diagrams

#### USB KVM Cable Connection

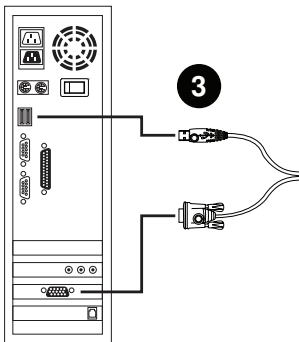

#### PS/2 KVM Cable Connection

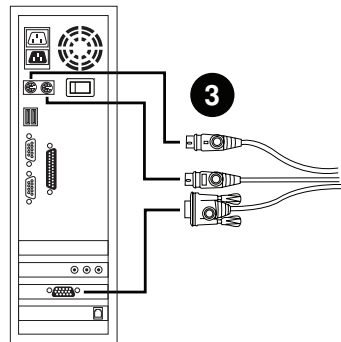

## Daisy Chaining

---

To control even more computers, up to 31 compatible KVM switches can be daisy-chained from the first CL5808 / CL5816 (see *Supported KVM Switches*, page 83, for details). In a complete installation, as many as 256 / 512 computers can be controlled from the CL5808 / CL5816. Tables showing the relation between the number of computers and the number of units needed to control them are provided on page 81 in the Appendix.

To set up a daisy chain installation, first, make sure that power to all devices to be connected has been turned off. Refer to the daisy chain installation diagram on page 23, as you do the following:

1. For having the LCD KVM switch CL5808 / CL5816 as the first station, connect the *chain out* port of CL5808 / CL5816 to the *chain in* port of the next station using a daisy chain cable set (described in the *Cables* section, page 5).

For the rest of the daisy chain, connect the *chain out* port of the chained station to the *chain in* port of the consecutive station using a daisy chain cable set. Make sure the KVM switches (stations) have their *chain in* port connected to a previous station.

- 
- Note:**
1. The maximum distance between any two stations is 15 m.
  2. The total maximum distance from the first station to the last station is 100 m, regardless of the number of stations in the chain. The daisy-chain functionality is not guaranteed should any of the inter-station distances follow Note 1 above.
- 

2. Use compatible KVM cable sets to connect any available KVM port on the daisy chained switch to the keyboard, video and mouse ports of the computers you are installing. See *KVM Cable Installation Diagrams*, page 21.
3. Power up the installation according to the following procedure:
  - a) Power on the CL5808 / CL5816.
  - b) Power on each station on the installation in turn (second station, then third station, etc.).

In each case, wait for the station ID to be ascertained and displayed on the current station before powering on the next one.
  - c) After all the stations are turned on, power on the computers.

## Daisy Chain Installation Diagram

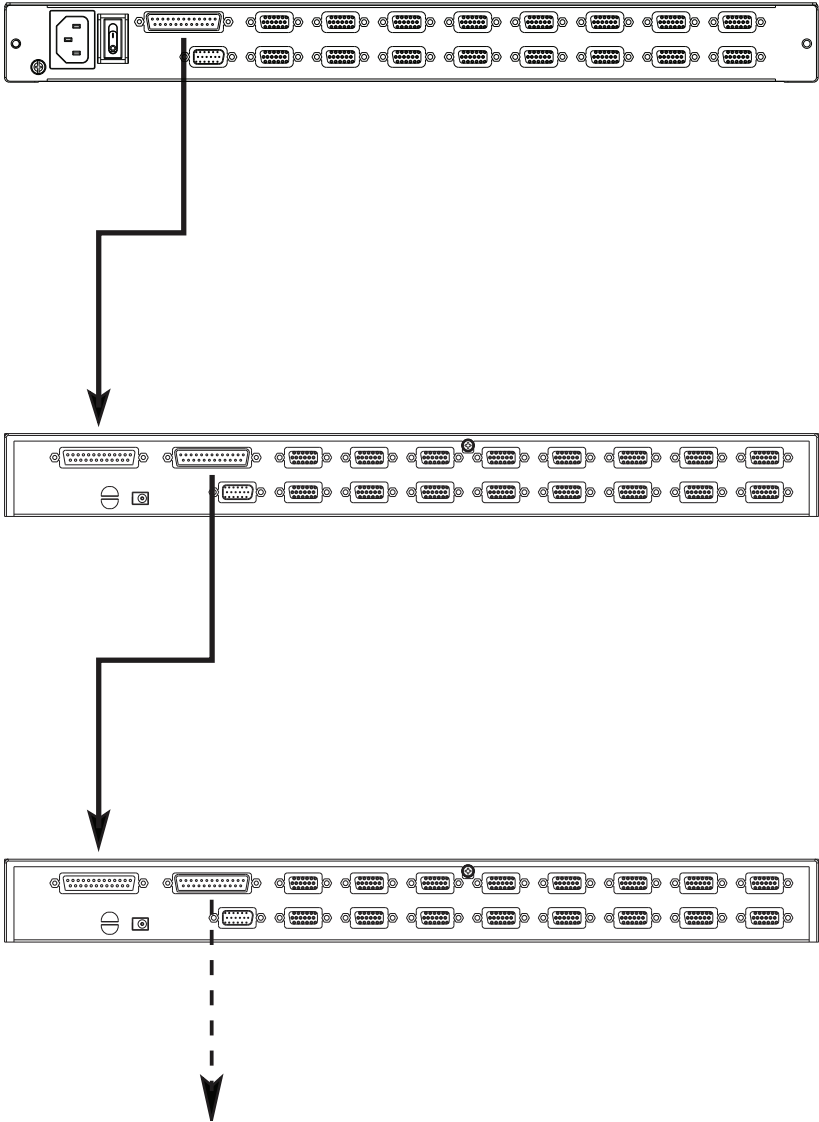

This Page Intentionally Left Blank

# Chapter 3

## Basic Operation

### Opening the Console

---

The CL5808/CL5816's console consists of two modules: an LCD display module located under the top cover, and a keyboard / touch pad module below the LCD module.

The modules can either be slid together, or independently. This allows you to have the LCD display available for viewing while the keyboard / touch pad module is conveniently out of the way when not in use.

### Opening Separately

1. Pull the release catches to release the console, and pull the top panel a few centimeters toward you. Once the console has been released, you can let go of the catches.

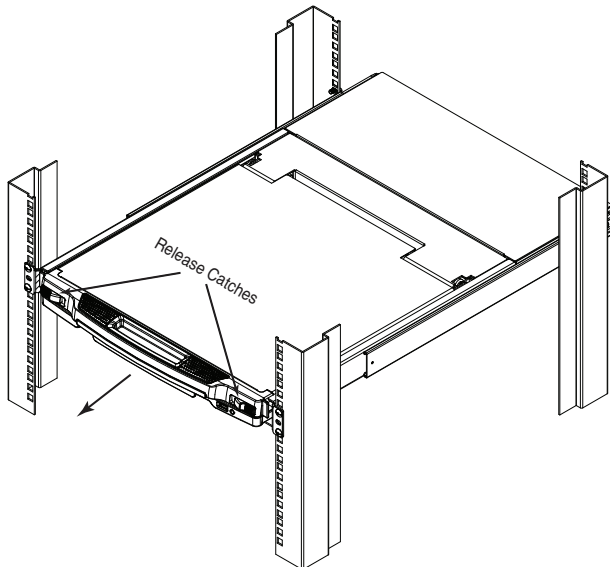

*(Continued from previous page.)*

2. Pull the top panel all the way out until it clicks into place.

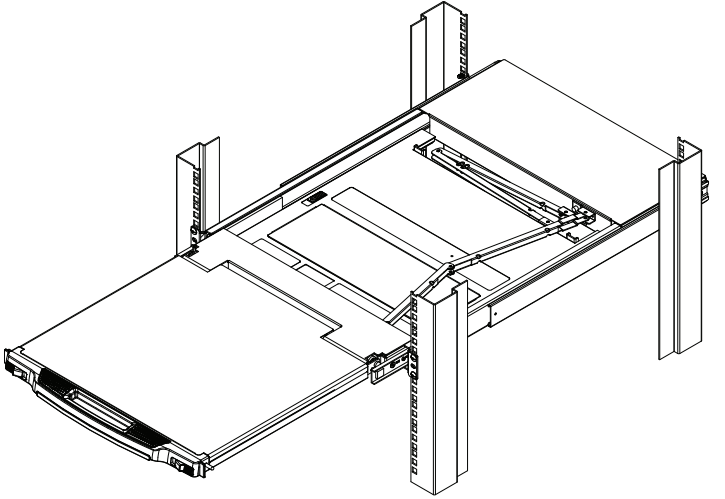

3. Rotate the top panel all the way back to expose the LCD screen.

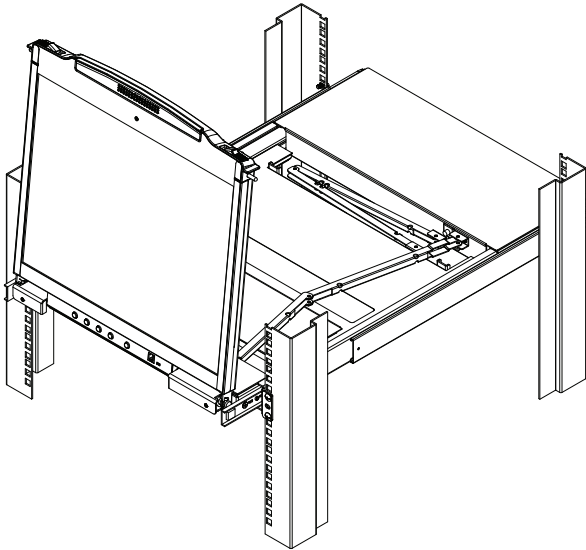

4. Reach underneath and pull the keyboard module all the way out until it clicks into place.

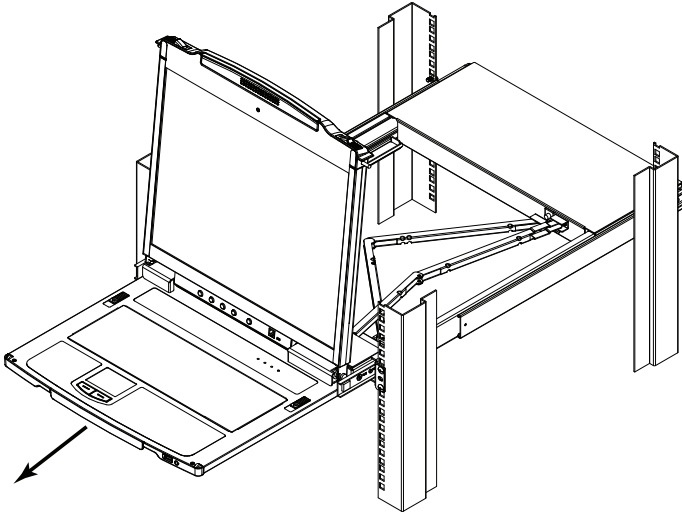

### **Opening Together**

Refer to the diagrams in the *Opening Separately* section as you do the following:

1. Pull the release catch and pull the top and bottom panels out until the keyboard module clicks into place.

---

**Note:** Once the console has been released, you can let go of the catch.

---

2. Pull the top panel the rest of the way out until it clicks into place.
3. Rotate the top panel all the way back to expose the LCD screen.

---

**Note:** Refer to the warning regarding placing excessive weight on the keyboard module on the following page.

---

## Closing the Console

---

1. Pull the release catches located on either side of the keyboard toward you to release the keyboard module, then slide the module slightly in.

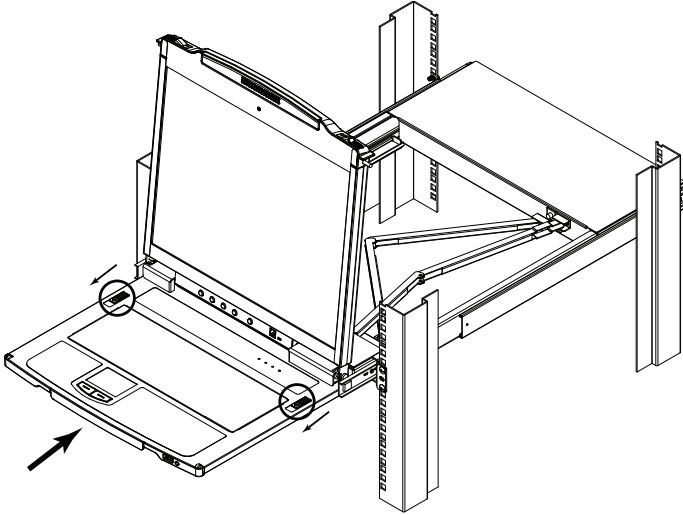

2. Let go of the catches. Using the front handle, push the keyboard module all the way in.

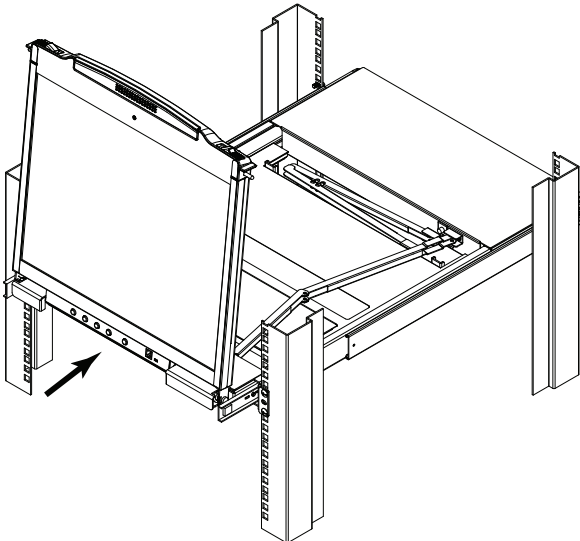



(Continued from previous page.)

3. Rotate the LCD module all the way down, then pull the rear catches to release the LCD module.

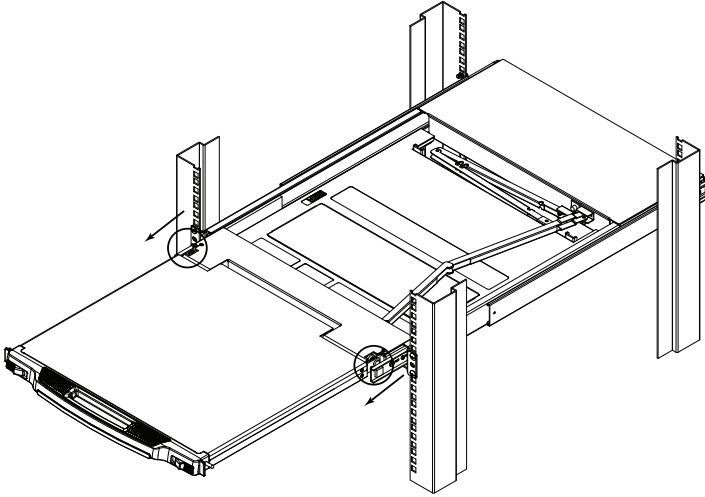

4. Using the front handle, push the module all the way in.

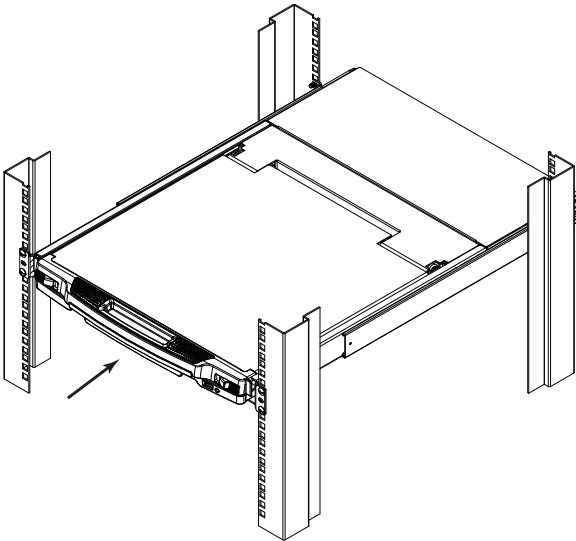

## Operating Precautions

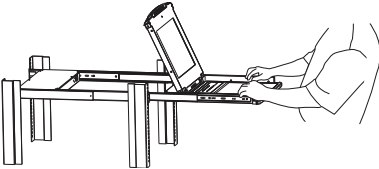
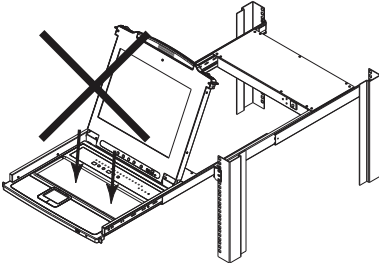

The maximum load bearing capacity of the keyboard module is 20 kg. Failure to heed the information below can result in damage to the keyboard module.

	<p><b>Right!</b></p> <p>Rest your hands and arms lightly on the keyboard module as you work.</p>
	<p><b>Wrong!</b></p> <ul style="list-style-type: none"><li>◆ <b>DO NOT</b> lean your body weight on the keyboard module.</li><li>◆ <b>DO NOT</b> place heavy objects on the keyboard module.</li></ul>

## Powering Off and Restarting

---

If it becomes necessary to power off the CL5808/CL5816, do the following before restarting it:

1. Shut down all the computers that are attached to the CL5808/CL5816.

---

**Note:** Unplug the power cords of any computers that have the *Keyboard Power On* function. Otherwise, the CL5808/CL5816 will still receive power from the computers.

---

2. Unplug the CL5808/CL5816 from its power source.
3. Wait 10 seconds, then plug the CL5808/CL5816 back in.
4. After the CL5808/CL5816 has started and ascertained its station ID, power on the computers.

---



**Note:** If you have shut down more than one station, power up the highest station first and work your way down to the lowest one.

---

## LCD OSD Configuration

### The LCD Buttons

The LCD OSD allows you to set up and configure the LCD display. Four buttons are used to perform the configuration, as described in the table, below:

Button	Function
MENU	<ul style="list-style-type: none"> <li>◆ When you have not entered the LCD OSD Menu function, pressing this button invokes the Menu function, and brings up the Main Menu.</li> <li>◆ When you have entered the LCD OSD Menu function, and have reached a setting choice with the navigation buttons, pressing this button brings up its adjustment screen.</li> </ul>
	When navigating through the menus, this button moves you Right or Up. When making an adjustment, it increases the value.
	When navigating through the menus, this button moves you Left or Down. When making an adjustment, it decreases the value.
EXIT	<ul style="list-style-type: none"> <li>◆ When you have not entered the LCD OSD Menu function, pressing this button performs an auto adjustment. An auto adjustment automatically configures all the settings for the LCD panel to what the OSD considers their optimum values to be.</li> <li>◆ When you have entered the LCD OSD Menu function, pressing this button exits the current menu and returns you to the previous menu. Use it to leave an adjustment menu when you are satisfied with the adjustment you made.</li> <li>◆ When you are at the Main Menu, pressing this button exits the LCD OSD.</li> </ul>

## **LCD Adjustment Settings**

An explanation of the LCD OSD adjustment settings is given in the table below:

<b>Setting</b>	<b>Explanation</b>
Brightness	Adjusts the background black level of the screen image.
Contrast	Adjusts the foreground white level of the screen image.
Phase	If pixel jitter or horizontal line noise is visible on the display, your LCD may have the wrong phase setting. Adjust the phase setting to eliminate these problems.
Clock	If vertical banding is visible on the display, your LCD may have the wrong clock setting. Adjust the clock setting to eliminate vertical banding.
H-Position	Positions the display area on the LCD panel horizontally (moves the display area left or right).
V-Position	Positions the display area on the LCD panel vertically (moves the display area up or down).
Color Temperature	Adjusts the color quality of the display. You can adjust the warmth value, color balance, etc. The <i>Adjust Color</i> selection has a further submenu that lets you fine tune the RGB values.
Language	Selects the language that the OSD displays its menus in.
OSD Duration	Lets you set the amount of time the OSD displays on the screen. If there is no input for the amount of time you choose, the OSD display turns off.
Reset	Resets the adjustments on all menus and submenus to their factory default settings.

**Note:** As an alternative to manually adjusting the LCD settings, you can have the LCD auto-adjusted for optimum display by pressing the Exit button. See *EXIT*, page 32

## Hot Plugging

---

The CL5808/CL5816 supports hot plugging – components can be removed and added back into the installation by unplugging and replugging their cables without the need to shut the unit down. In order for hot plugging to work properly, however, there are some procedures that need to be taken into account, as described in the following sections.

### **Hot Plugging Stations**

You can change a station's position by simply disconnecting it from the previous station it is connected to and reconnecting it to another switch in the chain. In order for the OSD menus to correspond to the change, you must reset the OSD. See *RESET STATION IDS*, page 47, for details.

### **Hot Plugging KVM Ports**

After switching KVM ports, in order for the OSD menus to correspond to the change, you must reconfigure the OSD information for the new port information. See *F3: SET*, page 42, and the port setting selections under the *F4 ADM* function, page 44, for details.

---

**Note:** If a computer's operating system doesn't support hot plugging, this function may not work properly.

---

### **Hot Plugging Console Ports**

The keyboard, monitor, and mouse can be hot plugged. When hot plugging the mouse, however, be aware of the following:

- ◆ If you unplug the mouse (to reset the mouse, for example), we recommend that you use the same mouse when you plug back in.
- ◆ If, after hot plugging (or at any other time), there is no response to keyboard and/or mouse input, perform a keyboard and mouse reset by pressing in the Reset switch (see page 9).

---

**Note:** If performing the keyboard/mouse reset doesn't resolve the problem, shut down all the stations and all the computers on the installation for 10 seconds, then restarted following the sequence given under *Powering Off and Restarting* on page 31.

---

- ◆ Some older operating systems may not support hot plugging.

## Port Switching

---

The CL5808/CL5816 provides three port switching methods to access the computers on the installation: Manual, an OSD (on-screen display) menu system, and Hotkeys. Manual port switching is discussed below. See Chapter 4, *OSD Operation* and Chapter 3, *Keyboard Port Operation* for more information.

### **Manual Port Switching**

#### **Station Selection**

The Station Navigation buttons are located on the Keyboard Module. Press and release the UP or Down button to move to the next or previous station. To cycle forward or backward through the installed Stations, press and hold the UP or DOWN button.

#### **Port Selection**

There are two methods for selecting the target port after you have selected the target station:

- ◆ If the keyboard module is not extended, you can use the Port Navigation buttons, located at the bottom left of the LCD module. Press the UP or DOWN button to move to the previous or next port. To cycle backward or forward through all the available ports on all the stations, keep pressing and releasing the UP or DOWN button.
- ◆ If the keyboard module is extended, press the port selection button (located at the top of the keyboard module – see page 8), that corresponds to the port you want to access. The SELECTED LED, built into the button, lights to indicate the currently selected port has the KVM focus.

## Port ID Numbering

---

Each computer on the installation is assigned a unique port ID. The port ID is a one or two segment number that is determined by the stage level and port number of the switch that the computer is connected to. The first segment represents the stage level of the switch (04, for example); the second segment represents the number of the port that the computer is plugged into.

For example, a computer that is connected to KVM port 3 of a switch that is in the 12th position of the daisy chain, would have a port ID of 12-03.

---

**Note:** Single digit numbers (1–9) are padded with a preceding zero (0).

---

## USB Peripheral Devices

---

A USB port, located on the keyboard module's front panel, is available to connect a USB peripheral device (flash drive, CD-ROM drive, printer, etc.) to the CL5808/CL5816. Any computer connected to the CL5808/CL5816 can access the USB peripheral on a one-at-a-time basis. The peripheral device is available to computers connected to the CL5808/CL5816 on the same level only, and is not available to computers connected to daisy chained switches.

The USB peripheral device is automatically detected on target computers when switching ports on the CL5808/CL5816. For example, when switching from a computer connected to port 1 to a computer connected to port 2, the peripheral device automatically disconnects from the computer on port 1 and connects to the computer on port 2.

---

**Note:** The USB peripheral function only works with USB cable set connections. It will not work with PS/2 cable set connections.

---



# Chapter 4

## OSD Operation

### Overview

---

The On Screen Display (OSD) is a menu-driven method to handle computer control and switching operations. All procedures start from the OSD main screen.

There are two ways to invoke the OSD:

1. Tap the OSD invocation key on the keyboard (see page 86), or
2. Tap the OSD Hotkey twice (default = *[Scroll Lock]*).

---

**Note:** To adjust OSD hotkey settings, see *OSD HOTKEY*, page 42.

---

### Manufacturing Number

The *MFG Number* (Manufacturing Number) is an internal serial number used by ATEN's factory and technical support staff to identify products. This number does not affect products' warranty. If your product requires after-sales services, you may provide the MFG Number to ATEN's sales or technical support staff to identify the product and model number.

### Logging In

---

The OSD incorporates a two-level (administrator / user) authorization procedure. Before the OSD main screen comes up, a login dialog box appears requesting a username and password.

If this is the first time that the OSD is being run, or if the password function has not been set, simply press **[Enter] [Enter]**. The OSD main screen is displayed in administrator mode, with full access to all functions, and can set up operations (including login credentials) as you like.

### OSD Main Screen

---

When you invoke the OSD, a screen similar to the one below appears:

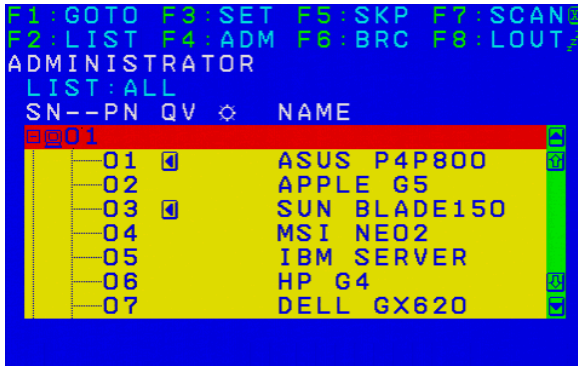

- 
- Note:**
1. The diagram depicts the administrator's main screen. The user main screen does not show the **F4** and **F6** functions, since these are reserved for the administrator and can't be accessed by users.
  2. The OSD always starts in list view, with the highlight bar at the same position it was in the last time it was closed.
  3. Only the ports that have been set accessible by the administrator for the current logged in user are visible (see *SET ACCESSIBLE PORTS*, page 45, for details).
  4. If the port list is collapsed, click on a switch number, or move the highlight bar to it then press the right arrow key to expand the list. Similarly, to collapse a switch's port list, click on the switch number, or move the highlight bar to it then press the left arrow key to collapse the list.
-

## OSD Main Screen Headings

The table below describes the OSD Main Screen headings.

Heading	Description
SN--PN	This column lists the port ID numbers (station number - port number) for all the KVM ports on the installation. The simplest method to access a particular computer is move the highlight bar to it, then press <b>[Enter]</b> .
QV	If a port has selected for quick view scanning (see <i>Set Quick View Ports</i> , page 46), an arrowhead displays in this column.
	The computers that are powered on and are online have a sun symbol in this column.
NAME	If a port has been given a name (see <i>Edit Port Names</i> , page 46), its name appears in this column.

## OSD Navigation

- ◆ To dismiss the menu, and deactivate OSD, click the **X** at the upper right corner of the OSD window; or press **[Esc]**.
- ◆ To log out, click **F8** at the top of the main screen, or press **[F8]**.
- ◆ To move up or down through the list one line at a time, click the up and down triangle symbols (**▲▼**) or use the up and down arrow keys. If there are more list entries than what can appear on the main screen, the screen will scroll.
- ◆ To move up or down through the list one screen at a time, click the up and down arrow symbols (**↑↓**), or use the **[Pg Up]** and **[Pg Dn]** keys. If there are more list entries than what can appear on the main screen, the screen will scroll.
- ◆ To bring the KVM focus to a port, double click it, or move the highlight bar to it then press **[Enter]**.
- ◆ After executing any action, you automatically go back to the menu one level above.

## OSD Functions

---

OSD functions are used to configure and control the OSD. For example, you can rapidly switch to any port, scan selected ports, limit the list you wish to view, designate a port as a quick view port, create or edit a port name, or make OSD setting adjustments.

To access an OSD function:

1. Either click a function key field at the top of the main screen, or press a corresponding function key on the keyboard.
2. In the submenus that appear, make your choice either by double clicking it, or moving the highlight bar to it, then pressing **[Enter]**.
3. Press **[Esc]** to return to the previous menu level.

### **F1: GOTO**

Clicking the **F1** field or pressing **[F1]** activates the GOTO function. GOTO allows you to switch directly to a port either by keying in the port's *Name*, or its *Port ID*.

- ♦ To use the name method, key in **1**; key in the port's *Name*; then press **[Enter]**.
- ♦ To use the port ID method, key in **2**; key in the *Port ID*; then press **[Enter]**.

---

**Note:** You can key in a partial name or port ID. In that case, the screen will show all the computers that the user has *View* rights to (see *SET ACCESSIBLE PORTS*, page 45), that match the name or port ID pattern, regardless of the current list settings (see *F2 LIST*, page 41, for details).

---

To return to the OSD main screen without making a choice, press **[Esc]**.

## **F2: LIST**

This function lets you broaden or narrow the scope of which ports the OSD displays on the main screen. The submenu choices and their meanings are given in the table below.

<b>Choice</b>	<b>Meaning</b>
ALL	Lists all of the ports on the installation that have been set accessible by the administrator for the current logged in user.
QUICK VIEW	Lists only the ports that have been selected as quick view ports (see <i>SET ACCESSIBLE PORTS</i> , page 45).
POWERED ON	Lists only the ports that have their attached computers powered on.
QUICK VIEW + POWERED ON	Lists only the ports that have been selected as quick view ports (see <i>SET QUICK VIEW PORTS</i> , page 46), and that have their attached computers powered on.

Move the highlight bar to the choice you want, then press **[Enter]**. An icon appears before the choice to indicate that it is the currently selected one.

### **F3: SET**

This function allows the administrator and each user to set up his own working environment. A separate profile for each is stored by the OSD and is activated according to the username that was provided during login.

To change a setting:

1. Double-click it; or move the highlight bar to it, then press **[Enter]**.
2. After you select an item, a submenu with further choices appears. To make a selection, either double-click it; or move the highlight bar to it, then press **[Enter]**. An icon appears before the selected choice to indicate which one it is. The settings are explained in the following table:

<b>Setting</b>	<b>Function</b>
OSD HOTKEY	Disables or selects which hotkey activates the OSD function:  <b>OFF, [Scroll Lock] [Scroll Lock] or [Ctrl] [Ctrl].</b>  <b>Note:</b> By default, this function is set to <i>[Scroll Lock] [Scroll Lock]</i> .
PORT ID DISPLAY POSITION	Allows each user to customize the position where the port ID appears on the screen. The default is the upper left corner, but users can choose to have it appear anywhere on the screen.  Use the mouse or the arrow keys plus Pg Up, Pg Dn, Home, End, and 5 (on the numeric keypad with Num Lock off), to position the port ID display, then double-click or press <b>[Enter]</b> to lock the position and return to the Set submenu.
PORT ID DISPLAY DURATION	Determines how long a port ID displays on the monitor after a port change has taken place. The choices are: <b>3 Seconds</b> (default) and <b>ALWAYS OFF</b> .
PORT ID DISPLAY MODE	Selects how the port ID is displayed: the port number plus the port name ( <b>PORT NUMBER + PORT NAME</b> ) (default); the port number alone ( <b>PORT NUMBER</b> ); or the port name alone ( <b>PORT NAME</b> ).
SCAN DURATION	Determines how long the focus dwells on each port as it cycles through the selected ports in Auto Scan mode (see <i>F7 SCAN</i> , page 49). Key in a value from 1–255 seconds, then press <b>[Enter]</b> . Default is 5 seconds; a setting of 0 disables the SCAN function.

*(Continues on next page.)*

(Continued from previous page.)

Setting	Function
SCAN-SKIP MODE	<p>Selects which computers will be accessed under skip mode (see <i>F5 SKP</i>, page 48), and Auto Scan mode (see <i>F7 SCAN</i>, page 49). Choices are:</p> <p><b>ALL</b> - All the ports which have been set accessible (see <i>SET ACCESSIBLE PORTS</i>, page 45);</p> <p><b>QUICK VIEW</b> - Only those ports which have been set accessible and have been selected as quick view ports (see <i>SET QUICK VIEW PORTS</i>, page 46);</p> <p><b>POWERED ON</b> - Only those ports which have been set accessible and are powered on;</p> <p><b>QUICK VIEW + POWERED ON</b> - Only those ports which have been set accessible and have been selected as quick view ports and are powered on. The default is ALL.</p> <p><b>Note:</b> The quick view choices only show up on the administrator's screen, since only he has <i>Quick View</i> setting rights (see <i>SET QUICK VIEW PORTS</i>, page 46, for details).</p>
SCREEN BLANKER	<p>If there is no input from the console for the amount of time set with this function, the screen is blanked. Key in a value from 1–30 minutes, then press <b>[Enter]</b>. The default setting of 0 disables this function.</p>
HOTKEY COMMAND MODE	<p>Enables / disables the Hotkey command function in case a conflict occurs with programs running on the computers.</p>
HOTKEY	<p>Sets the keyboard shortcut for invoking <i>Hotkey Mode</i> (see page 42). Choices are: <b>[NUM LOCK] + [-]</b> (minus) (default), and <b>[CTRL] + [F12]</b>.</p>
OSD LANGUAGE	<p>Sets the language used in the OSD. Choices are: English, German, Japanese, Simplified Chinese and Traditional Chinese.</p>
TOUCHPAD	<p>Enables / disables the touchpad.</p>

## **F4: ADM**

F4 is an administrator only function. It allows the administrator to configure and control the overall operation of the OSD. To change a setting double-click it, or use the up and down arrow keys to move the highlight bar to it then press **[Enter]**.

After you select an item, a submenu with further choices to select from appears. Double-click an item, or move the highlight bar to it then press **[Enter]**. An icon appears before the selected item so that you know which one it is. The settings are explained in the following table:

<b>Setting</b>	<b>Function</b>
SET USER LOGIN	<p>Use this function to set login mode, usernames, passwords and fingerprints for the administrator and users.</p> <p>SET USERNAME AND PASSWORD</p> <ul style="list-style-type: none"> <li>◆ Usernames and passwords for one administrator and four users can be set.</li> <li>◆ After you select the administrator field or one of the user fields, a screen that allows you to key in the username and password appears. Usernames and passwords can be from 1 to 16 characters long and can consist of any combination of letters and numbers (A–Z, 0–9) and some additional keys (* ( ) + : - , ? . / space).</li> <li>◆ For each individual, key in the username and password, confirm the password, then press <b>[Enter]</b>.</li> <li>◆ To modify or delete a previous username and/or password, use the backspace key to erase individual letters or numbers. Press <b>[Enter]</b> when done.</li> <li>◆ Usernames and passwords are not case sensitive. Usernames are displayed in capital letters in the OSD.</li> </ul> <p>SET FINGERPRINT:</p> <p><b>Note:</b> This setting is only available on models with a fingerprint reader.</p> <p>Selecting this option enables the fingerprint reader to record fingerprints.</p> <p>Fingerprints can be used in conjunction with, or in place of, a username and password when logging in. Although up to 10 fingerprints can be scanned for each user account, a maximum of 20 fingerprints can be stored on the switch, depending on the size of the fingerprint data file.</p>



Setting	Function
SET USER LOGIN (continued)	<p><b>To record a fingerprint:</b></p> <ol style="list-style-type: none"> <li>1. Select an item from the list and double-click it, or move the highlight bar to it and press <b>[Enter]</b>.</li> <li>2. Swipe the selected finger across the reader 3 times as directed.</li> <li>3. Once the fingerprint is successfully recorded, you have the option of recording another.</li> </ol> <p><b>Note:</b></p> <ol style="list-style-type: none"> <li>1. Pressing F1 deletes the highlighted fingerprint from memory.</li> <li>2. Pressing F2 deletes all fingerprints for the current user from memory.</li> <li>3. Pressing F3 allows you to edit the name of the highlighted fingerprint.</li> <li>4. Pressing F5 deletes the highlighted fingerprint's name.</li> </ol> <p>SET LOGIN MODE:</p> <p><b>Note:</b> This setting is only available on models with a fingerprint reader.</p> <p>Use this function to select the user login mode: either <b>PASSWORD OR FINGERPRINT</b> (where either the username and password or a fingerprint can be used to log in), or <b>PASSWORD + FINGERPRINT</b> (where the username and password followed by a fingerprint must be used).</p> <p>In <b>PASSWORD + FINGERPRINT</b> mode, if the fingerprint does not match the username, the user will not be able to log in. This mode provides better security than <b>PASSWORD OR FINGERPRINT</b> mode.</p>
SET ACCESSIBLE PORTS	<p>This function allows the administrator to define user access to the computers on the installation on a port-by-port basis.</p> <p>For each user, select the target port; then press the <b>[Spacebar]</b> to cycle through the choices: <b>F</b> (full access), <b>V</b> (view only), or blank. Repeat until all access rights have been set, then press <b>[Enter]</b>. The default is <b>F</b> for all users on all ports.</p> <p><b>Note:</b></p> <ol style="list-style-type: none"> <li>1. A blank setting means that no access rights are granted. The port will not show up on the user's LIST on the main screen.</li> <li>2. The administrator always has full access to all ports.</li> </ol>
SET LOGOUT TIMEOUT	<p>If there is no input from the console for the amount of time set with this function, the user is automatically logged out. A login is necessary before the console can be used again.</p> <p>This enables other users to gain access to the computers when the original user is no longer accessing them, but has forgotten to log out. To set the timeout value, key in a number from 1–180 minutes, then press <b>[Enter]</b>. The default setting of 0 disables this function.</p>

Setting	Function
EDIT PORT NAMES	<p>To help remember which computer is attached to a particular port, every port can be given a name. This function allows the administrator to create, modify, or delete port names. To edit a port name:</p> <ol style="list-style-type: none"> <li>Click the port, or use the navigation keys to move the highlight bar to it, then press <b>[Enter]</b>.</li> <li>Key in the new port name, or modify/delete the old one. The maximum number of characters allowed for the port name is 12. Legal characters include: <ul style="list-style-type: none"> <li>◆ All alpha characters: <b>A–Z</b></li> <li>◆ All numeric characters: <b>0–9</b></li> <li>◆ <b>* ( ) + : - , ? . /</b> and <b>Space</b></li> </ul> <p>Case does not matter; OSD displays the port name in all capitals no matter how they were keyed in.</p> </li> <li>When you have finished editing, press <b>[Enter]</b> to have the change take effect. To abort the change, press <b>[Esc]</b>.</li> </ol>
RESTORE DEFAULT VALUES	<p>This function is used to undo all changes and return the setup to the original factory default settings (see <i>OSD FACTORY DEFAULT SETTINGS</i>, page 69) except for the port name list, username and password information, which are saved.</p>
CLEAR THE NAME LIST	<p>This function clears the port name list.</p>
ACTIVATE BEEPER	<p>Choices are <b>Y</b> (on), or <b>N</b> (off). When activated, the beeper sounds whenever a port is changed; when activating the Auto Scan function (see <i>F7 SCAN</i>, page 49); or an invalid entry is made on an OSD menu. The default is <b>Y</b>.</p>
SET QUICK VIEW PORTS	<p>This function lets the administrator select which ports to include as quick view ports.</p> <ul style="list-style-type: none"> <li>◆ To select/deselect a port as a quick view port, double-click the port, or use the navigation keys to move the highlight bar to it, then press <b>[Spacebar]</b>.</li> <li>◆ When a port has been selected as a quick view port, an icon displays in the QV column of the LIST on the main screen.</li> <li>◆ If one of the quick view options is chosen for the LIST view (see <i>F2 LIST</i>, page 41), only a port that has been selected here will display on the list.</li> <li>◆ If one of the quick view options is chosen for auto scanning (see <i>SCAN/SKIP MODE</i>, page 43), only a port that has been selected here will be auto scanned.</li> </ul> <p>The default has no ports selected for quick view.</p>

Setting	Function
RESET STATION IDS	<p>If you change the position of one of the stations in the daisy chain, the OSD settings will no longer correspond to the new location. This function directs the OSD to rescan the station positions of the entire installation and updates the OSD so that the OSD station information corresponds to the new physical layout.</p> <p><b>Note:</b> Only the station numbers get updated. Except for the port names, all administrator settings (such as SET ACCESSIBLE PORTS, SET QUICK VIEW PORTS, etc.) must be input again for all of the computers affected by the change.</p>
SET OPERATING SYSTEM	<p>This function allows the administrator to define the operating system for the computer connected to each KVM port. The default is WIN (PC compatible).</p> <p>To set the port operating system:</p> <ol style="list-style-type: none"> <li>1. From the list, select the port for which you wish to set the computer's operating system.</li> <li>2. Set the operating system by pressing <b>[Spacebar]</b> to cycle through WIN, MAC, SUN, or OTHER .</li> <li>3. Press <b>[Esc]</b> to exit. The operating system you selected is assigned to the KVM port.</li> </ol>
FIRMWARE UPGRADE	<p>In order to upgrade the CL5808/CL5816 firmware (see page 63), you must first enable Firmware Upgrade mode with this setting.</p> <p>When you bring up this menu, the current firmware version levels are displayed. Select <b>Y</b> to enable Firmware Upgrade mode, or <b>N</b> to leave this menu without enabling it.</p>
SET KEYBOARD LANGUAGE	<p>Sets the language for the computer keyboard attached to the KVM port. To select a keyboard language, double-click it, or use the navigation keys to move the highlight bar to it, then press <b>[Enter]</b>.</p> <p>Choices are: AUTO (default), ENGLISH (UK), ENGLISH (US), FRENCH, GERMAN (GER.), GERMAN (SWISS), GREEK, HUNGARIAN, ITALIAN, JAPANESE, KOREAN, RUSSIAN, SPANISH, SWEDISH, GREEK, and TRADITIONAL CHINESE.</p>
SET CONSOLE MODE	<p>This setting selects which consoles (internal/external) are enabled:</p> <p><b>0</b> – Both consoles enabled  <b>1</b> – LCD console only  <b>2</b> – External console only</p> <p>Use the spacebar to cycle to the choice you want. The default is 0.</p>

## **F5: SKP**

Clicking the **F5** field or pressing **[F5]** invokes Skip mode. This function enables you to easily skip backward or forward – switching the console focus from the currently active computer port to the previous or next available one.

- ◆ The selection of computers to be available for skip mode switching is made with the *Scan-Skip* mode setting under the **F3: SET** function (see page 42).
- ◆ When you are in skip mode:
  - press [ ← ] to switch to the previous computer in the list
  - press [ → ] to switch to the next computer in the list
  - press [ ↑ ] to switch to the last computer on the previous station in the list
  - press [ ↓ ] to switch to the first computer on the next station in the list.

---

**Note:** When you skip, you only skip to the previous or next available computer that is in the *Scan-Skip* mode selection (page 43).

---

- ◆ If a port has been selected for *Scan-Skip* mode, when the focus switches to that port a left/right triangle symbol appears before its port ID display.
- ◆ While skip mode is in effect, the console will not function normally. You must exit skip mode in order to regain control of the console.
- ◆ To exit skip mode, press **[Spacebar]** or **[Esc]**.

## **F6: BRC**

F6 is an administrator only function. Clicking the **F6** field, or pressing **[F6]**, invokes *Broadcast* (BRC) mode. When this function is in effect, commands sent from the console are broadcast to all available computers on the installation.

This function is particularly useful for operations that need to be performed on multiple computers, such as performing a system wide shutdown, installing or upgrading software, etc.

- ◆ While BRC mode is in effect, a speaker symbol appears before the port ID display of the port that currently has the console focus.
- ◆ While BRC mode is in effect, the mouse will not function normally. You must exit BRC mode in order to regain control of the mouse.
- ◆ To exit BRC mode, invoke the OSD (with the OSD Hotkey), then click the **F6** field, or press **[F6]**, to turn BRC mode off.

## **F7: SCAN**

Clicking the **F7** field or pressing **[F7]** invokes *Auto Scan* mode. This function allows you to automatically switch among the available computers at regular intervals so that you can monitor their activity without having to take the trouble of switching yourself.

- ◆ The selection of computers to be included for auto scanning is made with the *Scan-Skip* mode setting under the **F3: SET** function (see page 43).
- ◆ The amount of time that each port displays for is set with the *Scan Duration* setting under the **F3: SET** function (see page 42). When you want to stop at a particular location, press the **[Spacebar]** to stop scanning.
- ◆ If the scanning stops on an empty port, or one where the computer is attached but is powered Off, the monitor screen will be blank, and the mouse and keyboard will have no effect. After the *Scan Duration* time is up, the scan function will move on to the next port.
- ◆ As each computer is accessed, an **S** appears in front of the port ID display to indicate that it is being accessed under *Auto Scan* mode.
- ◆ While *Auto Scan* mode is in effect, the console will not function normally. You must exit *Auto Scan* mode in order to regain control of the console.
- ◆ While you are in *Auto Scan* mode, you can pause the scanning in order to keep the focus on a particular computer either by pressing **[P]**, or with a left click of the mouse. See *Pausing Auto Scan*, page 54, for details.

- ◆ To exit *Auto Scan* mode, press the [Spacebar] or [Esc].

## **F8: LOUT**

Clicking the **F8** field, or pressing [F8] logs you out of OSD control of the computers, and blanks the console screen. This is different from simply pressing [Esc] when you are at the main screen to deactivate the OSD. With this function you must log in all over again to regain access to the OSD, whereas with [Esc], all you have to do to reenter the OSD is tap the OSD Hotkey.

- 
- Note:**
1. When you reenter the OSD after logging out, the screen stays blank except for the OSD main screen. You must input your username and password before you can continue.
  2. If you reenter the OSD after logging out, and immediately use [Esc] to deactivate the OSD without having selected a port from the OSD menu, a null port message displays on the screen. The OSD Hotkey will bring up the main OSD screen.
-

# Chapter 5

## Keyboard Port Operation

### Hotkey Port Control

---

Hotkey port control allows you to provide KVM focus to a particular computer directly from the keyboard. The CL5808/CL5816 provides the following Hotkey port control features:

- ◆ Selecting the Active Port
- ◆ Auto Scan Mode Switching
- ◆ Skip Mode Switching
- ◆ Computer Keyboard / Mouse Reset

The following settings can also be controlled in *Hotkey* mode:

- ◆ Setting the Beeper
- ◆ Setting the Quick Hotkey
- ◆ Setting the OSD Hotkey
- ◆ Setting the Port Operating System
- ◆ Restoring the OSD Default Values

## Hotkey Mode

---

### Invoking Hotkey Mode

All Hotkey operations begin by invoking *Hotkey* mode. There are two key sequences – a default and an alternate – that can be used to invoke Hotkey Mode, but only one of them can be active at a time:

1. The Default: *Num Lock* and *Minus*

To invoke Hotkey mode with the default key sequence, do the following:

1. Hold down the **[Num Lock]** key.
2. Press and release the **[Minus]** key.
3. Release the **[Num Lock]** key.

2. The Alternate: *Control* and *F12*

To invoke Hotkey mode with the alternate key sequence, do the following:

1. Hold down the **[Ctrl]** key.
2. Press and release the **[F12]** key.
3. Release the **[Ctrl]** key.

---

**Note:** 1. *Hotkey Command Mode* must be enabled in the settings (see page 43).

2. When invoking Hotkey Mode, be sure to use the active sequence.
- 

### Hotkey Mode Active

When the *Hotkey* mode is active:

- ♦ A command line appears on the monitor screen. The command line prompt is the word *Hotkey:* in white text on a blue background, and displays the subsequent Hotkey information that you key in.
- ♦ Ordinary keyboard and mouse functions are suspended – only Hotkey compliant keystrokes and mouse clicks (described in the sections that follow), can be input.

### Exiting Hotkey Mode

Press **[Esc]** to exit *Hotkey* mode.



## Selecting the Active Port

---

Each KVM port is assigned a unique port ID (see *Port ID Numbering*, page 34). You can directly access any computer on the installation with a Hotkey combination that specifies the port ID of the KVM port that the computer is connected to. To access a computer using Hotkeys, do the following:

1. Invoke Hotkey mode (see page 52).
2. Key in the port ID.

The port ID numbers display on the command line as you key them in. If you make a mistake, use [**Backspace**] to erase the error.

3. Press [**Enter**].

After you press [Enter], the KVM focus switches to the designated computer and you automatically exit Hotkey mode.

---

**Note:** In Hotkey mode, the KVM focus does not switch to a port if an invalid switch or port number is entered. The Hotkey command line continues to display on the screen until you either enter a valid switch and port number combination, or exit Hotkey mode.

---

## **Auto Scan Mode**

---

*Auto Scan* automatically switches among all the KVM ports that are accessible to the user at regular intervals, so that their activity can be monitored automatically. (See *SCAN-SKIP MODE*, page 43 for information regarding accessible ports.)

### **Invoking Auto Scan**

To start *Auto Scan mode*, do the following:

1. Invoke Hotkey mode (see page 52).
2. Press **[A]**.
3. Press **[Enter]**

After pressing [Enter], you exit Hotkey mode, and enter *Auto Scan* mode. While *Auto Scan* mode is in effect, ordinary keyboard and mouse functions are suspended – only *Auto Scan* mode compliant keystrokes and mouse clicks can be input. You must exit *Auto Scan* mode in order to regain normal control of the console.

### **Exiting Auto Scan**

To exit *Auto Scan* mode press **[Esc]** or **[Spacebar]**. Automatic scanning stops and you return to normal console operation.

### **Pausing Auto Scan**

While you are in *Auto Scan* mode, you can pause the scanning in order to keep the focus on a particular computer.

In certain cases, *pausing* can be more convenient than exiting *Auto Scan* mode because when you *resume*, the scanning order starts from the point you paused. If, by contrast, you exited in order to focus on a particular computer, when you restarted scanning would start over from the first computer of the installation.

To pause *Auto Scan* mode, press **[P]** or left click with the mouse. While *auto scan* mode is paused, the command line displays:

Auto Scan: Paused.

To resume *Auto Scanning* from where you paused, press any key or left click.

## Skip Mode

---

*Skip Mode* allows you to switch between computers in order to monitor them manually. You can dwell on a particular port for as long as you like – as opposed to auto scanning, which automatically switches the port focus after a fixed interval.

### Invoking Skip Mode

To start *Skip* mode, do the following:

1. Invoke Hotkey mode (see page 52).
2. Press an **[Arrow]** key.

Once you press an arrow key, you automatically exit Hotkey mode and enter *Skip* mode where you can switch ports as follows:

←	Skips to the first accessible port. (See <i>SCAN–SKIP MODE</i> , page 43, for information regarding accessible ports.)
→	Skips to the next accessible port.
↑	Skips to the last accessible port of the previous station.
↓	Skips to the first accessible port of the next station.

Once you are in *Skip* mode, you can continue skipping by pressing the arrow keys. You do not have to use the Hotkey invocation combination again.

While *Skip* mode is in effect, ordinary keyboard and mouse functions are suspended – only *Skip* mode compliant keystrokes can be input. You must exit *Skip* mode to regain normal control of the console.

### Exiting Skip Mode

1. To exit *Skip* mode, press **[Esc]** or **[Spacebar]**.

## Computer Keyboard/Mouse Reset

---

If either the keyboard or mouse stop functioning on the computer connected to the currently selected port, you can perform a keyboard/mouse reset on the computer with the following steps:

1. Invoke Hotkey mode (see page 52).
2. Press **[F5]**.

This function has the same effect as unplugging and replugging the keyboard and mouse on the target computer. After you press **[F5]** you automatically exit *Hotkey* mode and regain keyboard and mouse control on the computer connected to the KVM port.

If you fail to regain keyboard/mouse control on the computer after pressing **[F5]**, perform a system reset. For more information see *reset button*, page 9.

## Hotkey Beeper Control

---

The beeper (see Activate Beeper, page 46) can be toggled on and off with the following steps:

1. Invoke Hotkey mode (see page 52).
2. Press **[B]**.

After you press **[B]**, the beeper toggles on or off. The command line displays *Beeper On* or *Beeper Off* for one second; then the message disappears and you automatically exit Hotkey mode.

## Hotkey Invocation Key Selection

---

The keys used to invoke Hotkey Mode (see *Invoking Hotkey Mode*, page 52) can be toggled between

[Num Lock] + [-] and

[Ctrl] + [F12]

To toggle between them, do the following:

1. Invoke Hotkey mode (see page 52).
2. Press **[H]**.

After you press [H], the command line displays *HOTKEY HAS BEEN CHANGED* for one second; then the message disappears and you automatically exit Hotkey mode.

## OSD Hotkey Selection

---

The hotkey sequence used to call up the OSD can be toggled between  
OFF

[Scroll Lock] [Scroll Lock] or

[Ctrl] [Ctrl]

To toggle between them, do the following:

1. Invoke Hotkey mode (see page 52).
2. Press **[T]**.

After you press [T], the command line displays *HOTKEY HAS BEEN CHANGED* for one second; then the message disappears and you automatically exit Hotkey mode.

## Port OS Selection

---

A port's operating system can be configured so that it matches the one that is used by the computer attached to it. To configure a port's operating system configuration, do the following:

1. Invoke Hotkey mode (see page 52).
2. Refer to the table below.

Key	Description
F1	Sets the Port OS to Windows
F2	Sets the Port OS to Mac
F3	Sets the Port OS to Sun

3. Press the function key that corresponds to the OS configuration you want for the port.

After pressing a function key you automatically exit *Hotkey* mode.

## Set USB Speed

---

Users can use hotkeys to set the USB speed of the selected KVM port to low/full speed to comply with the connected computers.

1. Invoke Hotkey mode (see *Invoking Hotkey Mode* on page 52).
2. Press **[F11]**
3. Key in **[Function]**, where [Function] refers to one of the function keys in the following table:

Key	Description
L	Set the KVM port to low speed USB
F	Set the KVM port to full speed USB

4. Press **[Enter]**.

To set all KVM ports of the selected KVM station, add an **[A]** after the function key: Under Hotkey mode, press **[F11][L][A][Enter]** or **[F11][F][A][Enter]**.

## Restore the Default Values

---

This administrator only Hotkey restores the CL5808/CL5816 default values (see *RESTORE DEFAULT VALUES*, page 46). To restore the CL5808/CL5816 to its default values, do the following:

1. Invoke Hotkey mode (see page 52).
2. Press **[R]**.
3. Press **[Enter]**.

After you press [Enter], the command line displays *RESET TO DEFAULT SETTING* for three seconds; then the message disappears and you automatically exit Hotkey mode.

## Hotkey Summary Table

[Num Lock] + [-] or [Ctrl] + [F12]	[A] [Enter] or [Q] [Enter]	Enters <i>Auto Scan</i> mode.  When <i>Auto Scan</i> mode is in effect, [P] or left click pauses auto scanning.  When auto scanning is paused, pressing any key or another left click resumes auto scanning.
	[B]	Switches the beeper on or off.
	[Esc] or [Spacebar]	Exits Hotkey mode.
	[F1]	Sets the operating system configuration of the currently selected port to Windows
	[F2]	Sets the operating system configuration of the currently selected port to Mac
	[F3]	Sets the operating system configuration of the currently selected port to Sun
	[F5]	Performs a keyboard / mouse reset on the target computer.
	[H]	Switches the key combination used to enter the <i>Hotkey</i> mode keys between [Ctrl] + [F12] and [Num Lock] + [-].
	[R] [Enter]	This administrator-only Hotkey restores the switch's default values. See <i>RESTORE DEFAULT VALUES</i> , page 46.
	[Station #][Port #] [Enter]	Switches access to the computer that corresponds to the specified Station Number and Port Number.
	[F11] [F] [Enter]	Set the selected KVM port to full speed USB
	[F11] [L] [Enter]	Set the selected KVM port to low speed USB
	[F11] [F] [A] [Enter]	Set the selected KVM station to full speed USB
	[F11] [L] [A] [Enter]	Set the selected KVM station to low speed USB
	[T]	Switches the <i>OSD hotkey</i> between OFF, [Ctrl] [Ctrl], or [Scroll Lock] [Scroll Lock].
	[←]	Enters <i>Skip</i> mode and skips from the current port to the first accessible port previous to it.
	[→]	Enters <i>Skip</i> mode and skips from the current port to the next accessible port.
	[↑]	Enters <i>Skip</i> mode and skips from the current port to the last accessible port of the previous station.
	[↓]	Enters <i>Skip</i> mode and skips from the current port to the first accessible port of the next station.











# Chapter 6

## Keyboard Emulation

### Mac Keyboard

---

The PC compatible (101/104 key) keyboard can emulate the functions of the Mac keyboard. The emulation mappings are listed in the table below.

PC Keyboard	Mac Keyboard
[Shift]	Shift
[Ctrl]	Ctrl
	
[Ctrl] [1]	
[Ctrl] [2]	
[Ctrl] [3]	
[Ctrl] [4]	
[Alt]	Alt
[Print Screen]	F13
[Scroll Lock]	F14
	=
[Enter]	Return
[Backspace]	Delete
[Insert]	Help
[Ctrl] 	F15







---

**Note:** When using key combinations, press and release the first key (Ctrl), then press and release the activation key.

---

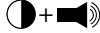
## Sun Keyboard

The PC compatible (101/104 key) keyboard can emulate the functions of the Sun keyboard when the Control key [Ctrl] is used in conjunction with other keys. The corresponding functions are shown in the table below.

PC Keyboard	Sun Keyboard
[Ctrl] [T]	Stop
[Ctrl] [F2]	Again
[Ctrl] [F3]	Props
[Ctrl] [F4]	Undo
[Ctrl] [F5]	Front
[Ctrl] [F6]	Copy
[Ctrl] [F7]	Open
[Ctrl] [F8]	Paste
[Ctrl] [F9]	Find
[Ctrl] [F10]	Cut
[Ctrl] [1]	
[Ctrl] [2]	
[Ctrl] [3]	
[Ctrl] [4]	
[Ctrl] [H]	Help
	Compose
	

**Note:** When using key combinations, press and release the first key (Ctrl), then press and release the activation key.

# Chapter 7

## The Firmware Upgrade Utility

### Introduction

---

The purpose of the Windows-based firmware upgrade utility is to provide an automated process for upgrading the CL5808/CL5816 and compatible adapter cable firmware. The program comes as part of a firmware upgrade package that is specific for each device.

As new firmware versions become available, new firmware upgrade packages are posted on our website. Check the website regularly to find the latest information and packages.

### Downloading the Firmware Upgrade Package

---

To download the firmware upgrade package:

1. From a computer that is not part of your KVM installation go to our website and choose the model name that relates to your device. A list of available firmware upgrade packages appears.
2. Choose the firmware upgrade package that you wish to install (usually the most recent) and download it to your computer.

## Preparation

---

To prepare for the firmware upgrade, do the following:

1. Use the *firmware upgrade cable* (provided with this unit), to connect a COM port on your computer to the *firmware upgrade port* of your switch.

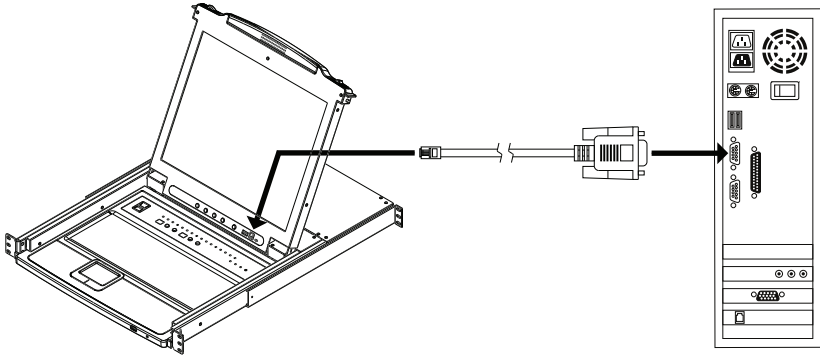

---

**Note:** On a daisy chained installation, the chained stations will automatically receive the upgrade via the daisy chain cables.

---

2. Shut down all the computers, but not the stations, on the KVM installation.
3. From your KVM switch console, login to the OSD as the administrator (see page 37) and select the **F4 ADM** function.
4. Scroll down to FIRMWARE UPGRADE. Press **[Enter]**, then press **[Y]** to invoke *Firmware Upgrade Mode* (see page 47.).

---

**Note:** During *Firmware Upgrade Mode*, the port LEDs will flash on and off.

---

---

## Starting the Upgrade

---

To upgrade the firmware:

1. Run the downloaded firmware upgrade package file either by double clicking the file icon, or by opening a command line and entering the full path to it.

The *Firmware Upgrade Utility* welcome screen appears:

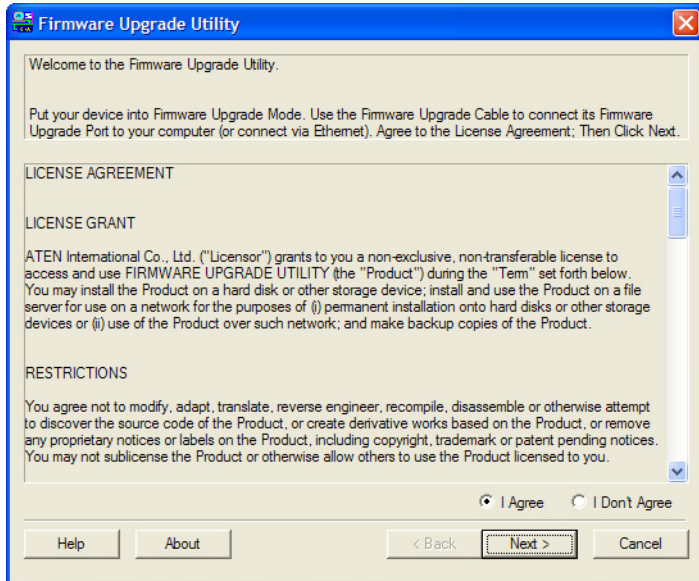

---

**Note:** The screens shown in this section are for reference only. The wording and layout of the actual screens put up by the *Firmware Upgrade Utility* may vary slightly from these examples.

---

2. Read and *Agree* to the License Agreement (enable the I Agree radio button).
3. Click **Next** to continue.

The *Firmware Upgrade Utility* main screen appears. The devices capable of being upgraded are listed in the *Device List* panel:

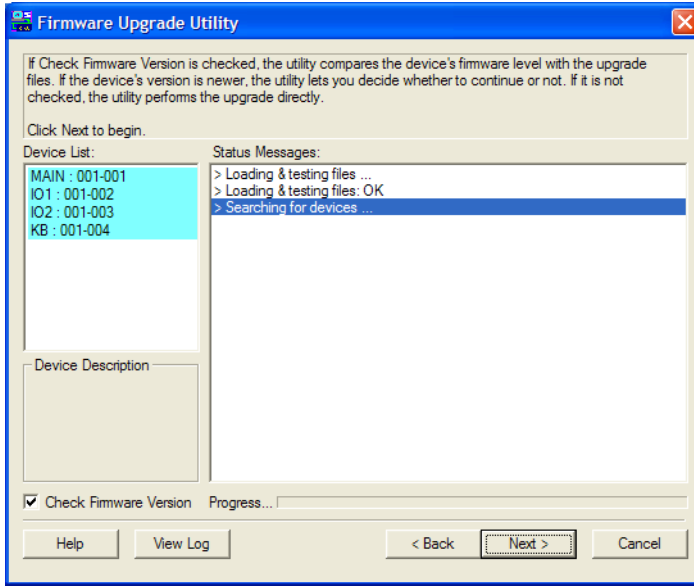

4. Click **Next** to perform the upgrade.

If you enabled *Check Firmware Version*, the utility compares the device's firmware level with that of the upgrade files. If it finds that the device's version is higher than the upgrade version, it brings up a dialog box informing you of the situation and gives you the option to continue or cancel.

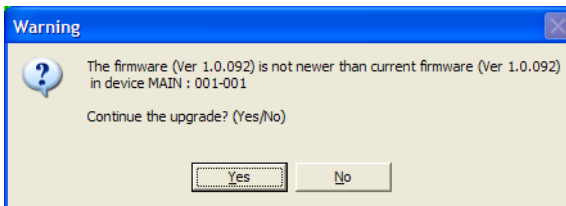

If you didn't enable *Check Firmware Version*, the utility installs the upgrade files without checking whether they are a higher level, or not.

As the upgrade proceeds, status messages appear in the *Status Messages* panel, and the progress toward completion is shown on the *Progress* bar.

## Upgrade Succeeded

After the upgrade has completed, a screen appears to inform you that the procedure was successful:

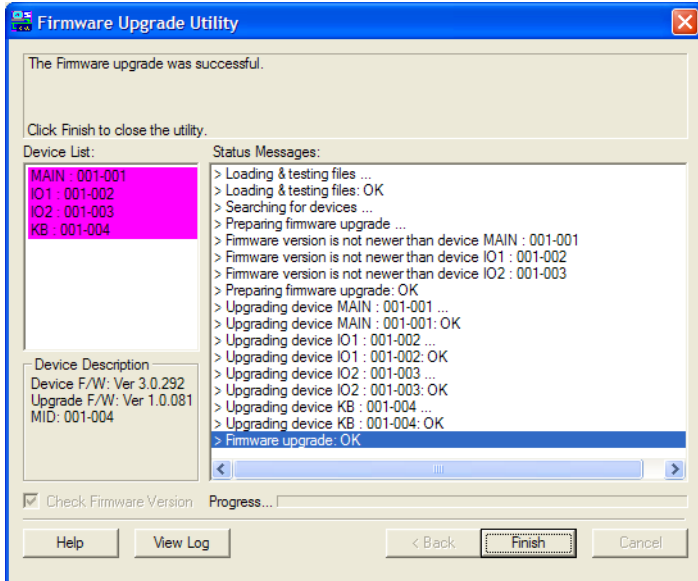

Click **Finish** to close the firmware upgrade utility.

## Upgrade Failed

---

If the firmware upgrade fails (*Upgrade Succeeded* screen does not appear), you can recover the situation.

Possible reasons for firmware upgrade failure are:

- ◆ When a firmware upgrade was manually aborted.
- ◆ When the unit's firmware becomes corrupted for some reason and you are unable to operate it.
- ◆ When a firmware upgrade procedure is interrupted.
- ◆ When a firmware upgrade procedure fails.

To recover a failed firmware upgrade, do the following:

1. Click **Cancel** to close the Firmware Upgrade Utility.
2. Power off the unit.
3. Connect the *firmware upgrade cable* to its *firmware upgrade port*.
4. Slide the *firmware upgrade switch* to the **Recover** position.
5. Power the unit back on and repeat the upgrade procedure (see *Starting the Upgrade* on page 65).
6. After the unit has been successfully upgraded, power it off, and slide the *firmware upgrade switch* back to the **Normal** position.
7. Power the unit back on again.



## Safety Instructions

---

### General

- ◆ This product is for indoor use only.
- ◆ Read all of these instructions. Save them for future reference.
- ◆ Follow all warnings and instructions marked on the device.
- ◆ Do not place the device on any unstable surface (cart, stand, table, or other surfaces). If the device falls, serious damage will result.
- ◆ Do not use the device near water.
- ◆ Do not place the device near, or over, heat radiators or heat vents.
- ◆ The device housing is provided with slots and openings to allow for adequate ventilation. To ensure reliable operation, and to protect against overheating, these openings must never be blocked or covered.
- ◆ The device should never be placed on a soft surface (bed, sofa, rug, or other soft surface) as this will block its ventilation openings. Likewise, the device should not be placed in an enclosure unless adequate ventilation has been provided.
- ◆ Never spill liquid of any kind on the device.
- ◆ Unplug the device from the wall outlet before cleaning. Do not use liquid or aerosol cleaners. Use a damp cloth for cleaning.
- ◆ The device should be operated from the type of power source indicated on the marking label. If you are not sure of the type of power available, consult your dealer or local power company.
- ◆ The device is designed for IT power distribution systems with 230V phase-to-phase voltage.
- ◆ To prevent damage to your installation it is important that all devices are properly grounded.
- ◆ The device is equipped with a 3-wire grounding type plug. This is a safety feature. If you are unable to insert the plug into the outlet, contact your electrician to replace your obsolete outlet. Do not attempt to circumvent the purpose of the grounding-type plug. Always follow your local/national wiring codes.
- ◆ Do not allow anything to rest on the power cord or cables. Route the power cord and cables so that they cannot be stepped on or tripped over.

- ◆ If an extension cord is used with this device make sure that the total of the ampere ratings of all products used on this cord does not exceed the extension cord ampere rating. Make sure that the total of all products plugged into the wall outlet does not exceed 15 amperes.
- ◆ To help protect your system from sudden, transient increases and decreases in electrical power, use a surge suppressor, line conditioner, or un-interruptible power supply (UPS).
- ◆ Never push objects of any kind into or through cabinet slots. They may touch dangerous voltage points or short-circuit parts resulting in a risk of fire or electrical shock.
- ◆ Do not attempt to service the device yourself. Refer all servicing to qualified service personnel.
- ◆ If the following conditions occur safely remove the power to the wall outlet, then unplug the device and bring it to qualified service personnel for repair.
  - ◆ The power cord or plug has become damaged or frayed.
  - ◆ Liquid has been spilled into the device.
  - ◆ The device has been exposed to rain or water.
  - ◆ The device has been dropped, or the cabinet has been damaged.
  - ◆ The device exhibits a distinct change in performance, indicating a need for service.
  - ◆ The device does not operate normally when the operating instructions are followed.
- ◆ Only adjust those controls that are covered in the operating instructions. Improper adjustment of other controls may result in damage that could require extensive work by a qualified technician to repair.
- ◆ Do not connect the RJ-11 connector marked “UPGRADE” to any type of telephone network.

---

## **Rack Mounting**

- ◆ Before working on the rack, make sure that the stabilizers are secured to the rack, extended to the floor, and that the full weight of the rack rests on the floor. Install front and side stabilizers on a single rack or front stabilizers for joined multiple racks before working on the rack.
- ◆ Always load the rack from the bottom up, and load the heaviest item in the rack first.
- ◆ Make sure that the rack is level and stable before extending a device from the rack.
- ◆ Use caution when pressing the device rail release latches and sliding a device into or out of a rack; the slide rails can pinch your fingers.
- ◆ After a device is inserted into the rack, carefully extend the rail into a locking position, and then slide the device into the rack.
- ◆ Do not overload the AC supply branch circuit that provides power to the rack. The total rack load should not exceed 80 percent of the branch circuit rating.
- ◆ Make sure that all equipment used on the rack – including power strips and other electrical connectors – is properly grounded.
- ◆ Ensure that proper airflow is provided to devices in the rack.
- ◆ Ensure that the operating ambient temperature of the rack environment does not exceed the maximum ambient temperature specified for the equipment by the manufacturer.
- ◆ Do not step on or stand on any device when servicing other devices in a rack.
- ◆ **Caution:** Slide/rail (LCD KVM) mounted equipment is not to be used as a shelf or a work space.



## Consignes de sécurité

---

### Général

- ♦ Ce produit est destiné exclusivement à une utilisation à l'intérieur.
- ♦ Veuillez lire la totalité de ces instructions. Conservez-les afin de pouvoir vous y référer ultérieurement.
- ♦ Respectez l'ensemble des avertissements et instructions inscrits sur l'appareil.
- ♦ Ne placez jamais l'unité sur une surface instable (chariot, pied, table, etc.). Si l'unité venait à tomber, elle serait gravement endommagée.
- ♦ N'utilisez pas l'unité à proximité de l'eau.
- ♦ Ne placez pas l'unité à proximité de ou sur des radiateurs ou bouches de chaleur.
- ♦ Le boîtier de l'unité est doté de fentes et d'ouvertures destinées à assurer une ventilation adéquate. Pour garantir un fonctionnement fiable et protéger l'unité contre les surchauffes, ces ouvertures ne doivent jamais être bloquées ou couvertes.
- ♦ L'unité ne doit jamais être placée sur une surface molle (lit, canapé, tapis, etc.) car ses ouvertures de ventilation se trouveraient bloquées. De même, l'unité ne doit pas être placée dans un meuble fermé à moins qu'une ventilation adaptée ne soit assurée.
- ♦ Ne renversez jamais de liquides de quelque sorte que ce soit sur l'unité.
- ♦ Débranchez l'unité de la prise murale avant de la nettoyer. N'utilisez pas de produits de nettoyage liquide ou sous forme d'aérosol. Utilisez un chiffon humide pour le nettoyage de l'unité.
- ♦ L'appareil doit être alimenté par le type de source indiqué sur l'étiquette. Si vous n'êtes pas sûr du type d'alimentation disponible, consultez votre revendeur ou le fournisseur local d'électricité.
- ♦ Afin de ne pas endommager votre installation, vérifiez que tous les périphériques sont correctement mis à la terre.
- ♦ L'unité est équipée d'une fiche de terre à trois fils. Il s'agit d'une fonction de sécurité. Si vous ne parvenez pas à insérer la fiche dans la prise murale, contactez votre électricité afin qu'il remplace cette dernière qui doit être obsolète. N'essayez pas d'aller à l'encontre de l'objectif de la fiche de terre. Respectez toujours les codes de câblage en vigueur dans votre région/pays.

- 
- ◆ L'équipement doit être installé à proximité de la prise murale et le dispositif de déconnexion (prise de courant femelle) doit être facile d'accès.
  - ◆ La prise murale doit être installée à proximité de l'équipement et doit être facile d'accès.
  - ◆ Veillez à ce que rien ne repose sur le cordon d'alimentation ou les câbles. Acheminez le cordon d'alimentation et les câbles de sorte que personne ne puisse marcher ou trébucher dessus.
  - ◆ En cas d'utilisation d'une rallonge avec cette unité, assurez-vous que le total des ampérages de tous les produits utilisés sur cette rallonge ne dépasse pas l'ampérage nominal de cette dernière. Assurez-vous que le total des ampérages de tous les produits branchés sur la prise murale ne dépasse pas 15 ampères.
  - ◆ Pour contribuer à protéger votre système contre les augmentations et diminutions soudaines et transitoires de puissance électrique, utilisez un parasurtenseur, un filtre de ligne ou un système d'alimentation sans coupure (UPS).
  - ◆ Placez les câbles du système et les câbles d'alimentation avec précaution ; veillez à ce que rien ne repose sur aucun des câbles.
  - ◆ Lors du branchement ou du débranchement à des blocs d'alimentation permettant la connexion à chaud, veuillez respecter les lignes directrices suivantes:
  - ◆ Installez le bloc d'alimentation avant de brancher le câble d'alimentation à celui-ci.
  - ◆ Débranchez le câble d'alimentation avant de retirer le bloc d'alimentation.
  - ◆ Si le système présente plusieurs sources d'alimentation, déconnectez le système de l'alimentation en débranchant tous les câbles d'alimentation des blocs d'alimentation.
  - ◆ N'insérez jamais d'objets de quelque sorte que ce soit dans ou à travers les fentes du boîtier. Ils pourraient entrer en contact avec des points de tension dangereuse ou court-circuiter des pièces, entraînant ainsi un risque d'incendie ou de choc électrique.
  - ◆ N'essayez pas de réparer l'unité vous-même. Confiez toute opération de réparation à du personnel qualifié.
  - ◆ Si les conditions suivantes se produisent, débranchez l'unité de la prise murale et amenez-la à un technicien qualifié pour la faire réparer:
    - ◆ Le cordon d'alimentation ou la fiche ont été endommagés ou éraillés.
    - ◆ Du liquide a été renversé dans l'unité.
-

- ◆ L'unité a été exposée à la pluie ou à l'eau.
- ◆ L'unité est tombée ou le boîtier a été endommagé.
- ◆ Les performances de l'unité sont visiblement altérées, ce qui indique la nécessité d'une réparation.
- ◆ L'unité ne fonctionne pas normalement bien que les instructions d'utilisation soient respectées.
- ◆ N'utilisez que les commandes qui sont abordées dans le mode d'emploi. Le réglage incorrect d'autres commandes peut être à l'origine de dommages qui nécessiteront beaucoup de travail pour qu'un technicien qualifié puisse réparer l'unité.
- ◆ Ne connectez pas le connecteur RJ-11 portant la marque « Sensor » (Capteur) à un réseau de télécommunication public.

## **Montage sur bâti**

- ◆ Avant de travailler sur le bâti, assurez-vous que les stabilisateurs sont bien fixés sur le bâti, qu'ils sont étendus au sol et que tout le poids du bâti repose sur le sol. Installez les stabilisateurs avant et latéraux sur un même bâti ou bien les stabilisateurs avant si plusieurs bâtis sont réunis, avant de travailler sur le bâti.
- ◆ Chargez toujours le bâti de bas en haut et chargez l'élément le plus lourd en premier.
- ◆ Assurez-vous que le bâti est à niveau et qu'il est stable avant de sortir une unité du bâti.
- ◆ Agissez avec précaution lorsque vous appuyez sur les loquets de libération du rail d'unité et lorsque vous faites coulisser une unité dans et hors d'un bâti ; vous pourriez vous pincer les doigts dans les rails.
- ◆ Une fois qu'une unité a été insérée dans le bâti, étendez avec précaution le rail dans une position de verrouillage puis faites glisser l'unité dans le bâti.
- ◆ Ne surchargez pas le circuit de l'alimentation CA qui alimente le bâti. La charge totale du bâti ne doit pas dépasser 80 % de la capacité du circuit.
- ◆ Assurez-vous que tous les équipements utilisés sur le bâti, y-compris les multiprises et autres connecteurs électriques, sont correctement mis à la terre.
- ◆ Assurez-vous que les unités présentes dans le bâti bénéficie d'une circulation d'air suffisante.
- ◆ Assurez-vous que la température ambiante de fonctionnement de l'environnement du bâti ne dépasse pas la température ambiante maximale spécifiée pour l'équipement par le fabricant.
- ◆ Ne marchez sur aucun appareil lors de la maintenance d'autres appareils d'un bâti.
- ◆ **Attention:** Glisser / rail (LCD KVM) monté l'équipement ne doit pas être utilisé comme une étagère ou un espace de travail.



## Technical Support

---

### International

- ◆ For online technical support – including troubleshooting, documentation, and software updates: **<http://eservice.aten.com>**
- ◆ For telephone support, *Telephone Support*, page iv

### North America

Email Support		<a href="mailto:support@aten-usa.com">support@aten-usa.com</a>
Online Technical Support	Troubleshooting Documentation Software Updates	<a href="http://www.aten-usa.com/support">http://www.aten-usa.com/support</a>
Telephone Support		1-888-999-ATEN ext 4988 1-949-428-1111

When you contact us, please have the following information ready beforehand:

- ◆ Product model number, serial number, and date of purchase.
- ◆ Your computer configuration, including operating system, revision level, expansion cards, and software.
- ◆ Any error messages displayed at the time the error occurred.
- ◆ The sequence of operations that led up to the error.
- ◆ Any other information you feel may be of help.



# Specifications

Function		CL5808N	
<b>Computer Connections</b>	Direct	8	
	Max	256 (via Daisy Chain)	
<b>Port Selection</b>		OSD, Hotkey, Pushbutton	
<b>Connectors</b>	KVM Ports	8 x SPHD Female (Yellow)	
	Daisy Chain Port	1 x DB-25 Male	
	Firmware Upgrade	1 x RJ-11 Female	
	Power	1 x IEC 60320/C14	
	External Console Port	1 x SPHD Male (Yellow)	
	External Mouse Port	1 x USB Type-A Female (Front)	
	USB Port	1 x USB Type-A Female (Front)	
<b>Switches</b>	Port Selection	2 x Pushbuttons (LCD) 8 x Pushbuttons (Keyboard)	
	Station Selection	2 x Pushbuttons	
	Reset	1 x Semi-recessed Pushbutton	
	Firmware Upgrade	1 x Slide Switch	
	Power	1 x Rocker Switch	
	LCD Control	4 x Pushbuttons	
	LCD Power	1 x LED Pushbutton	
<b>LEDs</b>	On Line	8 (Orange)	
	Selected	8 (Green)	
	Station ID	2 x 7-segment LED Displays (Orange)	
	Power	1 (Dark Green)	
	Lock		1 x Num Lock (Green)
			1 x Caps Lock (Green)
			1 x Scroll Lock (Green)
LED Illumination Light	1 x LED Illumination Light		

Function		CL5808N
<b>Panel Spec</b>	LCD Module	19" TFT-LCD
	Resolution	1280 x 1024 @ 75 Hz
	Response Time	5 ms
	Viewing Angle	170° (H), 160° (V)
	Pixel Pitch	0.294 mm x 0.294 mm
	Supported Color	16.77 M Colors
	Contrast Ratio	1000 : 1
	Luminance	250 cd/m <sup>2</sup>
<b>Video</b>	Input Video Resolution	Up to 1920 x 1200 @ 60 Hz; 1280 x 1024 @ 75 Hz, DDC2B
<b>Scan Interval</b>		1–255 seconds
<b>Emulation</b>	Keyboard / Mouse	PS/2, USB
<b>Maximum Input Power Rating</b>		100–240V AC, 50-60 Hz, 1 A
<b>Power Consumption</b>		AC110V:25.2W:129BTU AC220V:27.2W:138BTU
<b>Environmental</b>	Operating Temp.	0 – 50 °C
	Storage Temp.	-20 – 60 °C
	Humidity	0–80% RH, Non-condensing
<b>Physical Properties</b>	Housing	Metal + Plastic
	Rail Type	Dual Rail
	Weight	14.48 kg (31.89 lb)
	Dimensions (L x W x H)	48.00 x 68.04 x 4.40 cm (18.90 X 26.79 X 1.73 in)

Function		CL5816N	
<b>Computer Connections</b>	Direct	16	
	Max	512 (via Daisy Chain)	
<b>Port Selection</b>		OSD, Hotkey, Pushbutton	
<b>Connectors</b>	KVM Ports	16 x SPHD Female (Yellow)	
	Daisy Chain Port	1 x DB-25 Male	
	Firmware Upgrade	1 x RJ-11 Female	
	Power	1 x IEC 60320/C14	
	External Console Port	1 x SPHD Male (Yellow)	
	External Mouse Port	1 x USB Type-A Female (Front)	
	USB Port	1 x USB Type-A Female (Front)	
<b>Switches</b>	Port Selection	2 x Pushbuttons (LCD) 16 x Pushbuttons (Keyboard)	
	Station Selection	2 x Pushbuttons	
	Reset	1 x Semi-recessed Pushbutton	
	Firmware Upgrade	1 x Slide Switch	
	Power	1 x Rocker Switch	
	LCD Control	4 x Pushbuttons	
	LCD Power	1 x LED Pushbutton	
<b>LEDs</b>	On Line	16 (Orange)	
	Selected	16 (Green)	
	Station ID	2 x 7-segment LED Displays (Orange)	
	Power	1 (Dark Green)	
	Lock		1 x Num Lock (Green)
			1 x Caps Lock (Green)
			1 x Scroll Lock (Green)
LED Illumination Light	1 x LED Illumination Light		

Function		CL5816N
<b>Panel Spec</b>	LCD Module	19" TFT-LCD
	Resolution	1280 x 1024 @ 75 Hz
	Response Time	5 ms
	Viewing Angle	170° (H), 160° (V)
	Pixel Pitch	0.294 mm x 0.294 mm
	Supported Color	16.77 M Colors
	Contrast Ratio	1000 : 1
	Luminance	250 cd/m <sup>2</sup>
<b>Video</b>	Input Video Resolution	Up to 1920 x 1200 @ 60 Hz; 1280 x 1024 @ 75 Hz, DDC2B
<b>Scan Interval</b>		1-255 seconds
<b>Emulation</b>	Keyboard / Mouse	PS/2, USB
<b>Maximum Input Power Rating</b>		100–240V AC, 50-60 Hz, 1 A
<b>Power Consumption</b>		AC110V:25.2W:129BTU AC220V:27.2W:138BTU
<b>Environmental</b>	Operating Temp.	0 – 50 °C
	Storage Temp.	-20 – 60 °C
	Humidity	0–80% RH, Non-condensing
<b>Physical Properties</b>	Housing	Metal + Plastic
	Rail Type	Dual Rail
	Weight	14.76 kg (32.54 lb)
	Dimensions (L x W x H)	48.00 x 68.04 x 4.40 cm (18.90 x 26.79 x 1.73 in)

## Connection Tables

The following tables indicate the relationship between the number of units and the number of computers that they control on a daisy chained installation.

### CL5808 to Compatible 8-Port Switches

No.	Computers	No.	Computers	No.	Computers	No.	Computers
1	1–8	9	65–72	17	129–136	25	193–200
2	9–16	10	73–80	18	137–144	26	201–208
3	17–24	11	81–88	19	145–152	27	209–216
4	25–32	12	89–96	20	153–160	28	217–224
5	33–40	13	97–104	21	161–168	29	225–232
6	41–48	14	105–112	22	169–176	30	233–240
7	49–56	15	113–120	23	177–184	31	241–248
8	57–64	16	121–128	24	185–192	32	249–256

### CL5808 to Compatible 16-Port Switches

No.	Computers	No.	Computers	No.	Computers	No.	Computers
1	1–8	9	121–136	17	249–264	25	377–392
2	9–24	10	137–152	18	265–280	26	393–408
3	25–40	11	152–168	19	281–296	27	409–424
4	41–56	12	169–184	20	297–312	28	425–440
5	57–72	13	185–200	21	313–328	29	441–456
6	73–88	14	201–216	22	329–344	30	457–472
7	89–104	15	217–232	23	345–360	31	473–488
8	105–120	16	233–248	24	361–376	32	489–504

**CL5816 to Compatible 8-Port Switches**

No.	Computers	No.	Computers	No.	Computers	No.	Computers
1	1–16	9	73–80	17	137–144	25	201–208
2	17–24	10	81–88	18	145–152	26	209–216
3	25–32	11	89–96	19	153–160	27	217–224
4	33–40	12	97–104	20	161–168	28	225–232
5	41–48	13	105–112	21	169–176	29	233–240
6	49–56	14	113–120	22	177–184	30	241–248
7	57–64	15	121–128	23	185–192	31	249–256
8	65–72	16	129–136	24	193–200	32	257–264

**CL5816 to Compatible 16-Port Switches**

No.	Computers	No.	Computers	No.	Computers	No.	Computers
1	1–16	9	129–144	17	257–272	25	385–400
2	17–32	10	145–160	18	273–288	26	401–416
3	33–48	11	161–176	19	289–304	27	417–432
4	49–64	12	177–192	20	305–320	28	433–448
5	65–80	13	193–208	21	321–336	29	449–464
6	81–96	14	209–224	22	337–352	30	465–480
7	97–112	15	225–240	23	353–368	31	481–496
8	113–128	16	241–256	24	369–384	32	497–512

## Supported KVM Switches

Up to 31 additional KVM switches can be daisy chained from the CL5808/CL5816 . ATEN / Altusen KVM switches that can be used when configuring a daisy chained installation are shown in the following table:

Model	Type
ACS1208 / ACS1216	8 /16 Port PS/2 KVM Switch
ACS1208A / ACS1216A	
CS1708 / CS1716	8 /16 Port USB KVM Switch
CS1708A / CS1716A	8 / 16 Port PS/2+USB KVM Switch
KH0116	16 Port High-Density KVM Switch
KH1508 / KH1516	8 / 16 Port High-Density KVM Switch
KH1508A / KH1516A	
KH3116	16 Port High-Density KVM Switch

- Note:**
1. The maximum distance between any two KVM switches in the daisy chain cannot exceed 15 meters.
  2. The maximum distance between the CL5808/CL5816 and the last switch in the daisy chain cannot exceed 100 meters.

## Clear Login Information

---

If you are unable to perform an Administrator login (because the Username and Password information has become corrupted, or you have forgotten it), you can clear the login information with the following procedure.

1. Power off the switch and remove the top cover from the unit chassis.
2. Short jumper **J17** (labeled *Default Password*) on the switch's main board

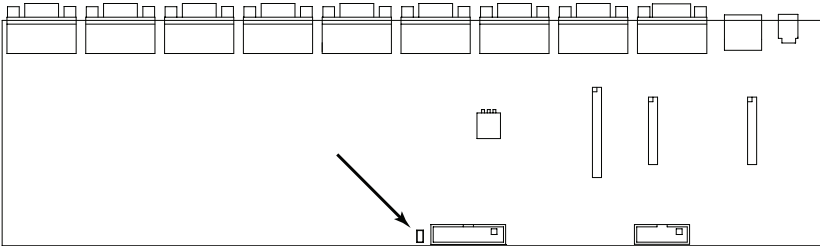

3. Power on the switch.

When you power the switch on, the following message appears on the LCD display:

```
USERNAME AND PASSWORD INFORMATION HAS BEEN CLEARED.  
PLEASE POWER OFF THE SWITCH, REMOVE THE JUMPER, CLOSE  
THE CASE, THEN RESTART.
```

After you start back up, the OSD login function acts exactly the way it did the first time the switch was run (see *Overview*, page 37) and you can reset passwords for the Administrators and Users.



## OSD Factory Default Settings

The factory default settings are as follows:

Setting	Default
OSD Hotkey	[Scroll Lock] [Scroll Lock]
Port ID Display Position	Upper Left Corner
Port ID Display Duration	3 Seconds
Port ID Display Mode	Port Number plus the Port Name
Scan Duration	5 Seconds
Scan/Skip Mode	All
Screen Blanker	0 (Disabled)
Logout Timeout	0 (Disabled)
Beeper	Y (Activated)
Accessible Ports	F (Full) for all users on all ports

## Troubleshooting

### Overview

Operation problems can be due to a variety of causes. The first step in solving them is to make sure that all cables are securely attached and seated completely in their sockets.

In addition, updating the product's firmware may solve problems that have been discovered and resolved since the prior version was released. If your product is not running the latest firmware version, we strongly recommend that you upgrade. See <x reference to Firmware Upgrade Chapter or Section>, for upgrade details.

Problem	Solution
There are ghost images on the external monitor.	The distance between the external console and the CL5808/CL5816 is too great. The maximum VGA cable distance should not exceed 20m and, in some cases, may need to be shorter. Replace the VGA cable with one of an appropriately short length.

## Keyboard Invocation Keys

---

Two dedicated keys are provided on the keyboard module to make it easy to invoke Hotkey mode and the OSD, as shown in the diagram, below



---

**Note:** These keys are toggles. Press them once to invoke the feature, press them again to exit.

---

---

## About SPHD Connectors

---



This product uses SPHD connectors for its KVM and/or Console ports. We have specifically modified the shape of these connectors so that only KVM cables that we have designed to work with this product can be connected.



## Limited Warranty

---

ATEN warrants its hardware in the country of purchase against flaws in materials and workmanship for a Warranty Period of two [2] years (warranty period may vary in certain regions/countries) commencing on the date of original purchase. This warranty period includes the [LCD panel of ATEN LCD KVM switches](#). Select products are warranted for an additional year (see [A+ Warranty](#) for further details). Cables and accessories are not covered by the Standard Warranty.

### What is covered by the Limited Hardware Warranty

ATEN will provide a repair service, without charge, during the Warranty Period. If a product is defective, ATEN will, at its discretion, have the option to (1) repair said product with new or repaired components, or (2) replace the entire product with an identical product or with a similar product which fulfills the same function as the defective product. Replaced products assume the warranty of the original product for the remaining period or a period of 90 days, whichever is longer. When the products or components are replaced, the replacing articles shall become customer property and the replaced articles shall become the property of ATEN.

To learn more about our warranty policies, please visit our website:  
<http://www.aten.com/global/en/legal/policies/warranty-policy/>

© Copyright 2022 ATEN® International Co., Ltd.  
Released: 2022-10-28

ATEN and the ATEN logo are registered trademarks of ATEN International Co., Ltd. All rights reserved. All other brand names and trademarks are the registered property of their respective owners.